

# ***DOT MATRIX PRINTER***

## **SP317/347F**

***INSTALLATION MANUAL  
GUIDE D'INSTALLATION  
AUFSTELLANLEITUNG  
MANUALE DI INSTALLAZIONE***





# TABLE OF CONTENTS

1. UNPACKING AND INSTALLATION .....	2
1-1. Unpacking .....	2
1-2. Handling Notes .....	2
2. PARTS IDENTIFICATION AND NOMENCLATURE .....	3
3. FERRITE CORE INSTALLATION .....	4
4. CONNECTING THE INTERFACE CABLE .....	6
4-1. Serial Interface Cable .....	6
4-2. Parallel Interface Cable .....	6
APPENDIX .....	25

# 1. UNPACKING AND INSTALLATION

## 1-1. Unpacking

After unpacking the unit, check that all the necessary accessories are included in the package.

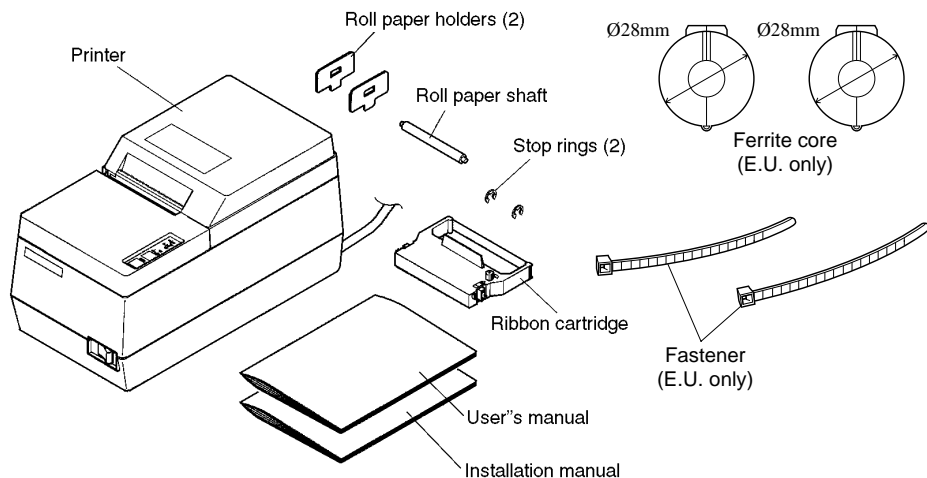


Fig. 1-1 Unpacking (SP317)

## 1-2. Handling Notes

1. Install the unit on a stand or table which has a flat, even surface.
2. Do not connect the AC power plug to the same outlet used for other electrical noise generating devices (such as an electrical motor, etc.)

### **IMPORTANT!**

Install the printer near an easily accessible socket-outlet.

3. Be careful not to drop paper clips, pins or other foreign objects into the unit as these could cause the printer to malfunction.
4. When cleaning the outer surface of the unit, wipe away dirt, foreign matter, etc., with a soft cloth, soaked in a neutral detergent.
5. Do not attempt to print when the paper or ribbon cartridge are not loaded in the printer as this could damage the print head.
6. Use only roll paper that is not glued to the core.
7. Do not open the front cover while printing (this is interpreted as a mechanical error and the printer will stop).

## 2. PARTS IDENTIFICATION AND NOMENCLATURE

### Front cover

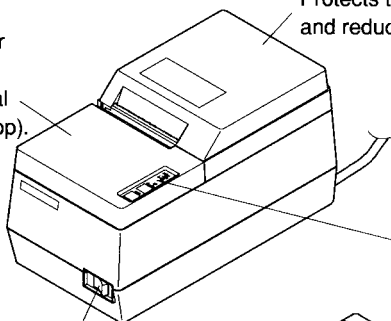
Protects the printer from dust and reduces noise.  
Do not open the front cover while printing (this is interpreted as a mechanical error and the printer will stop).

### Rear cover

Protects the printer from dust and reduces noise.

### Control panel

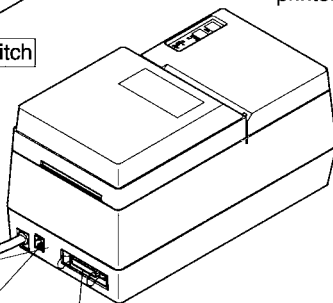
Features two control switches and three indicators to indicate printer status.



### Power switch

### AC power cord

Plugs into an outlet of the specified voltage.  
Shape of AC power plug will vary according to destinations.



### Peripheral unit drive circuit connector

Connects to peripheral units such as cash drawers, etc.  
Do not connect this to a telephone.

### Interface connector

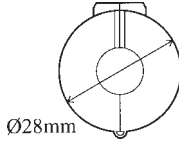
Connects the printer with host computer.

**Fig. 2-1 External view of the printer (SP317)**

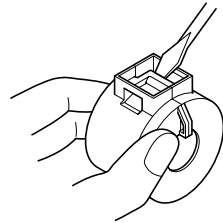
# 3. FERRITE CORE INSTALLATION

**NOTE:** Take special care when following the procedures listed below.

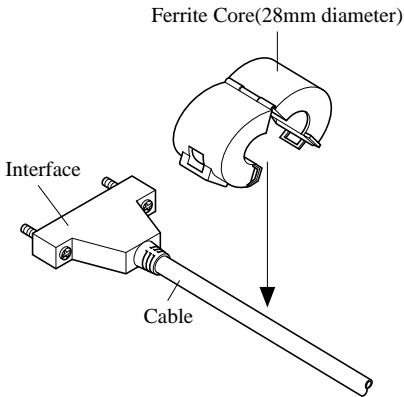
- Two ferrite core noise filters come packed with the printer. One is for the interface cable, while the other one is for the cash drawer drive cable.



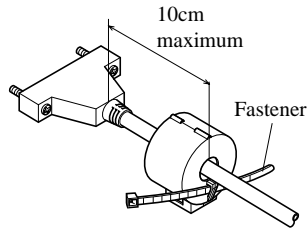
- The ferrite core is normally packed so it is open, as shown in Fig 3-2. If you find that a ferrite core is not open, use a pointed object to pry the plastic lock of the ferrite core apart (Fig 3-1). When you do, take care not to damage the ferrite core or the plastic lock.



**Fig. 3-1**

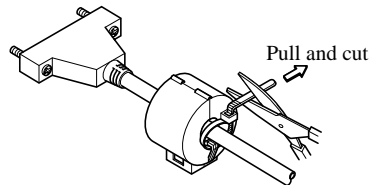


**Fig. 3-2**



Pass fastener through ferrite core.

**Fig. 3-3**



Pass fastener around cable and lock it.  
Cut off excess with scissors.

**Fig. 3-4**

## To install the interface cable ferrite core

- Clamp the ferrite core onto the interface cable as shown in Fig 3-2. Take care to avoid damaging the interface cable when installing the ferrite core. The ferrite core should be anchored firmly in place with the fastener that comes with it, as shown in Fig 3-3 and 3-4.

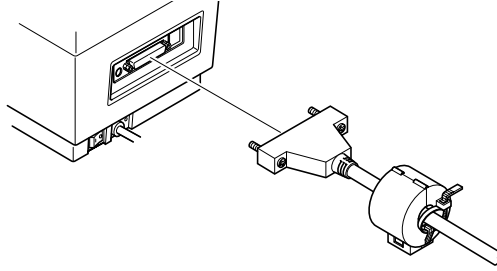


Fig. 3-5

## To install the cash drawer drive cable ferrite core

- Clamp the ferrite core onto the cash drawer drive cable, looping the cable as shown in Fig. 3-2.
  - When installing the ferrite core be careful not to damage the cable.
  - The ferrite core should be anchored firmly in place with the fastener that comes with it, as shown in Fig. 3-3 and Fig. 3-4.
  - Do not forget to loop the cable.

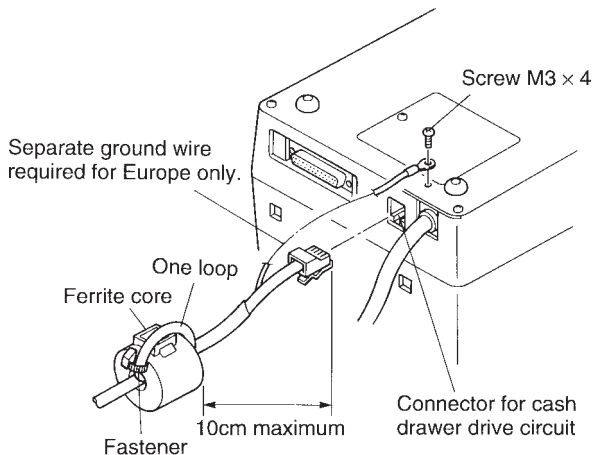


Fig. 3-6

## 4. CONNECTING THE INTERFACE CABLE

### 4-1. Serial Interface Cable

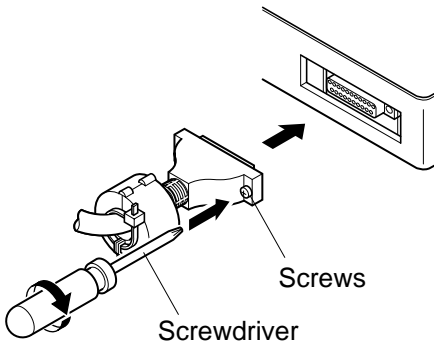


Fig. 4-1 Connecting the serial interface cable

- ① Turn off power for both the host computer and the printer.
- ② Insert the connector of the interface cable into the connector on the printer and the other end of the interface cable into the connector for the host computer.
- ③ Next, tighten the screws on the connectors.

### 4-2. Parallel Interface Cable

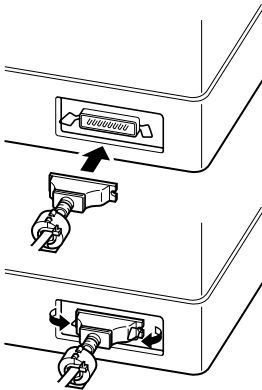


Fig. 4-2 Connecting the parallel interface cable

- ① Turn off the power for both the host computer and the printer.
- ② Insert one connector of the interface cable into the printer's connector and fasten it with the clasp, as shown in Fig. 4-2.
- ③ Insert the other terminal of the interface cable into the host computer's connector, and fasten it with the clasp.

# TABLE DES MATIÈRES

1. DÉBALLAGE ET INSTALLATION .....	8
1-1. Déballage .....	8
1-2. Remarques concernant la manipulation .....	8
2. IDENTIFICATION DES PIÈCES ET NOMENCLATURE .....	9
3. INSTALLATION DU NOYAU EN FERRITE .....	10
4. CONNEXION DU CÂBLE D'INTERFACE .....	12
4-1. Câble d'interface sériel .....	12
4-2. Câble d'interface parallèle .....	12
APPENDICE .....	25

*L'appendice n'est pas traduit.*

# 1. DÉBALLAGE ET INSTALLATION

## 1-1. Déballage

Après avoir déballé l'appareil, vérifiez si vous disposez bien de tous les accessoires illustrés ci-après.

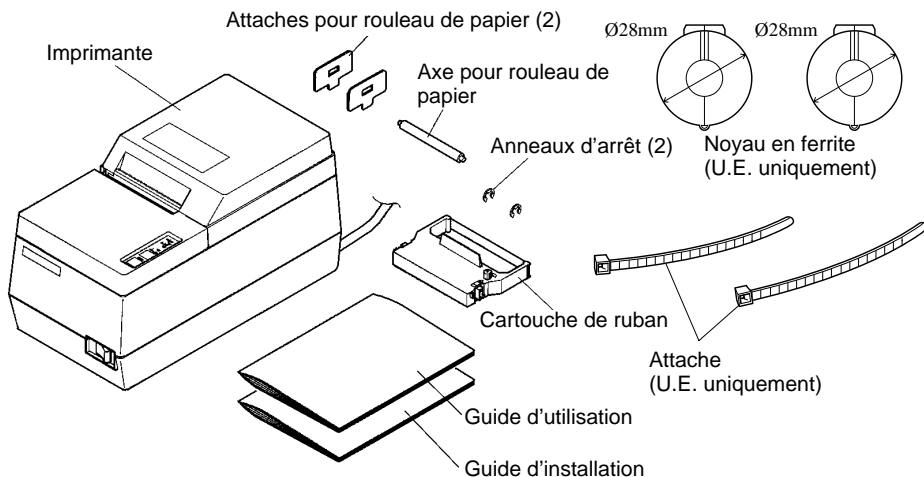


Fig. 1-1 Déballage (SP317)

## 1-2. Remarques concernant la manipulation

1. Installez l'appareil sur un support ou sur une table dont la surface est plate et uniforme.
2. Ne branchez pas l'appareil à la même prise secteur que d'autres appareils produisant des bruits électriques (appareils ayant un moteur électrique, etc.).  
**IMPORTANT !**  
Installez l'imprimante le plus près possible d'une prise secteur facilement accessible.
3. Veillez à ne pas laisser tomber des trombones, punaises ou autres objets dans l'appareil, cela risque de causer un mauvais fonctionnement.
4. Nettoyez la surface de l'imprimante à l'aide d'un chiffon doux humidifié et d'un détergent neutre.
5. Ne lancez pas l'impression si le papier ou la cartouche de ruban ne sont pas installés, sous peine d'endommager la tête d'impression.
6. N'utilisez jamais un rouleau de papier dont l'extrémité est collée au rouleau central.
7. N'ouvrez pas le cache avant de l'appareil pendant l'impression ; en effet cela serait interprété comme étant une erreur mécanique et l'impression s'interromprait automatiquement.

## 2. IDENTIFICATION DES PIÈCES ET NOMENCLATURE

### Cache avant

Protège l'imprimante de la poussière et réduit le bruit. N'ouvrez pas le cache avant pendant l'impression (cela est interprété comme étant une erreur mécanique et l'impression s'interrompt automatiquement).

### Cache arrière

Protège l'imprimante de la poussière et réduit le bruit.

### Panneau de commande

Comprend deux commutateurs et trois voyants indiquant l'état de l'imprimante.

### Commutateur de tension

### Cordon d'alimentation secteur

Se branche dans une prise femelle de la tension spécifiée. La présentation de la prise mâle varie selon les pays.

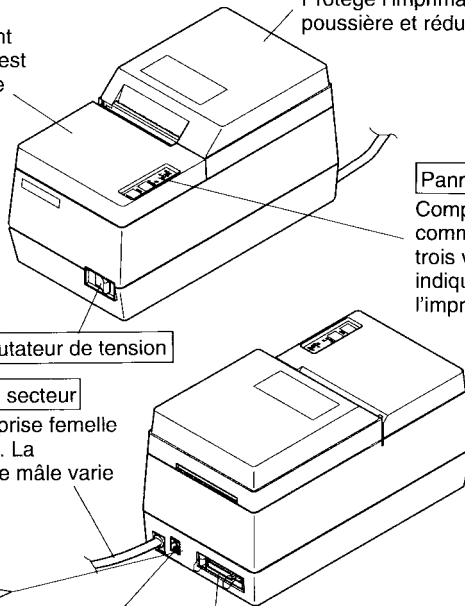


### Connecteur du circuit de commande d'appareils périphériques

Connecte l'imprimante à des appareils périphériques, tels des tiroirs-caisses, etc. Ne pas raccorder à un téléphone.

### Connecteur de l'interface

Connecte l'imprimante à l'ordinateur hôte.

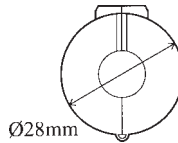


**Fig. 2-1** Vue externe de l'imprimante (SP317)

### 3. INSTALLATION DU NOYAU EN FERRITE

**N.B.:** Prendre des précautions spéciales en suivant les procédures indiquées ci-dessous:

- Deux filtres antibruit à tore de ferrite sont emballés avec l'imprimante. L'un est prévu pour le câble d'interface et l'autre doit être utilisé pour le câble de commande de la caisse enregistreuse.



- Le tore de ferrite est généralement livré ouvert comme indiqué à la Fig. 3-2. Si un tore de ferrite n'est pas ouvert, utiliser un objet pointu pour forcer le verrouillage en plastique du tore de ferrite (Fig. 3-1). Lorsque c'est le cas, prendre soin de ne pas endommager le tore de ferrite ni le verrouillage en plastique.

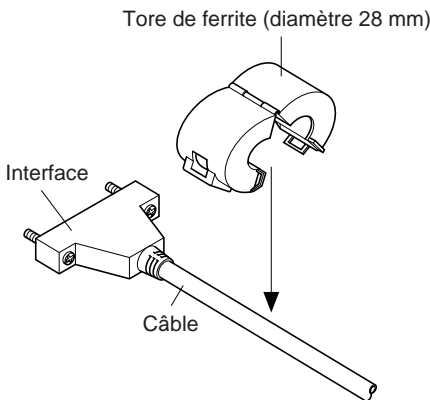


Fig. 3-2

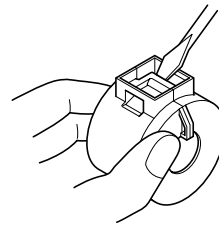
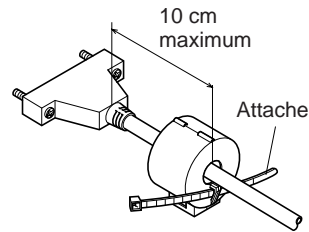
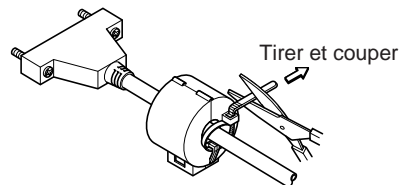


Fig. 3-1



Faire passer l'attache par le tore de ferrite.

Fig. 3-3



Couper toute partie qui dépasse avec des ciseaux.

Fig. 3-4

## Installation du tore de ferrite de câble d'interface

- Serrer le tore de ferrite au câble d'interface de la manière indiquée à la Fig. 3-2. Prendre les précautions d'usage pour éviter d'endommager le câble d'interface lors de l'installation du tore de ferrite. Il faut bien immobiliser le tore de ferrite au moyen de l'attache fournie, comme indiqué à la Fig. 3-3 et à la Fig. 3-4.

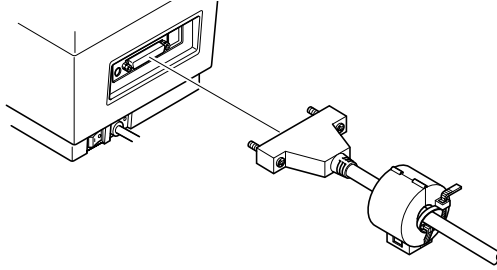


Fig. 3-5

## Installation du tore de ferrite de câble de commande de la caisse enregistreuse.

- Brider le noyau en ferrite au câble de commande du tiroir-caisse après avoir fait une boucle avec le câble, comme illustré à la figure 3-2.
  - En montant le noyau en ferrite, veillez à ne pas endommager le câble.
  - Le noyau en ferrite doit être maintenu fermement en place à l'aide de l'attache livrée, comme illustré aux figures 3-3 et 3-4.
  - Ne pas oublier de former une boucle avec le câble.

Un câble de mise à la terre séparé n'est nécessaire que pour l'Europe.

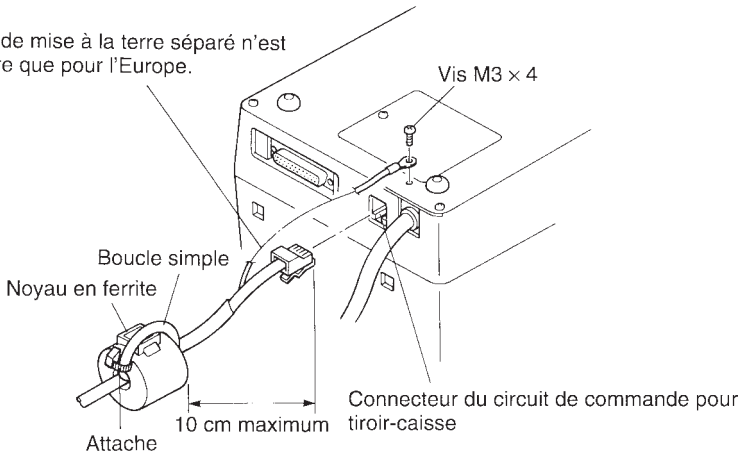


Fig. 3-6

## 4. CONNEXION DU CÂBLE D'INTERFACE

### 4-1. Câble d'interface sériel

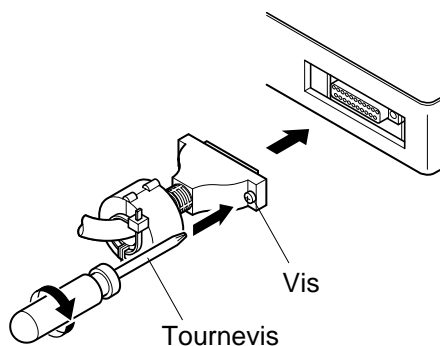


Fig. 4-1 Connexion du câble d'interface en série

- ① Mettez l'ordinateur hôte et l'imprimante hors tension.
- ② Insérez un des connecteurs du câble d'interface dans la prise de l'imprimante et l'autre dans la prise de l'ordinateur hôte.
- ③ Serrez ensuite les vis des connecteurs.

### 4-2. Câble d'interface parallèle

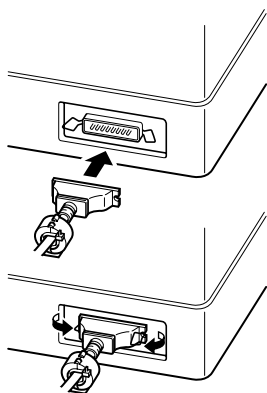


Fig. 4-2 Connexion du câble d'interface en parallèle

- ① Mettez l'ordinateur hôte et l'imprimante hors tension.
- ② Insérez un des connecteurs du câble d'interface dans la prise de l'imprimante et fixez-le grâce aux fermoirs, comme illustré à la fig. 4-2.
- ③ Insérez l'autre connecteur du câble d'interface dans la prise de l'ordinateur hôte, puis fixez-le également à l'aide des fermoirs.

# INHALTSVERZEICHNIS

1. AUSPACKEN UND AUFSTELLUNG .....	14
1-1. Auspacken .....	14
1-2. Hinweise zum Umgang .....	14
2. BESCHREIBUNG UND BEZEICHNUNG DER GERÄTETEILE ..	15
3. INSTALLATION DES FERRITKERNS .....	16
4. ANSCHLUSS DES SCHNITTSTELLENKABELS .....	18
4-1. Serielles Schnittstellenkabel .....	18
4-2. Paralleles Schnittstellenkabel .....	18
ANHANG .....	25

*Der Anhang erscheint nur im englischen Teil dieser Bedienungsanleitung*

# 1. AUSPACKEN UND AUFSTELLUNG

## 1-1. Auspacken

Überprüfen Sie den Kartoninhalt, und vergewissern Sie sich, daß alle unten abgebildeten Teile vorhanden sind.

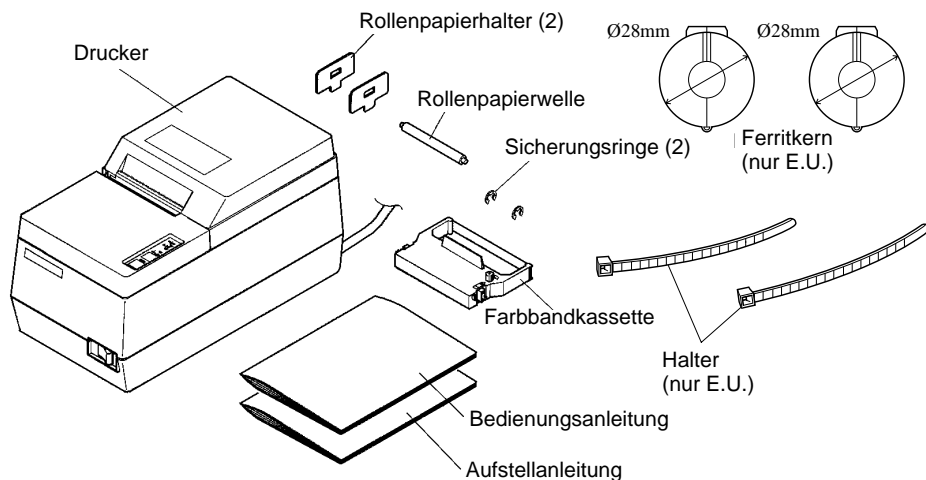


Abb. 1-1 Auspacken (SP317)

## 1-2. Hinweise zum Umgang

1. Stellen Sie den Drucker auf einem flachen, aber festen Untergrund auf.
2. Schließen Sie keine anderen elektrischen Geräte, die elektrische Störungen erzeugen (wie z.B. Elektromotoren) an die gleiche Steckdose an.

### WICHTIG!

Die verwendete Steckdose soll in der Nähe und frei zugänglich sein.

3. Achten Sie darauf, keine Papierclips oder anderen Fremdkörper in den Drucker fallen zu lassen. Diese können Betriebsstörungen oder Schäden am Gerät hervorrufen.
4. Bei der Reinigung des Geräteäußeren wischen Sie Flecken oder Schmutz mit einem weichen, mit neutralem Reinigungsmittel angefeuchteten Lappen ab.
5. Versuchen Sie nicht zu drucken, wenn kein Papier oder keine Farbbandkassette eingelegt ist, da sonst der Druckkopf beschädigt werden kann.
6. Verwenden Sie nur Rollenpapier, das nicht am Rollenkern festgeklebt ist.
7. Öffnen Sie nicht die Frontabdeckung während des Druckens (dies wird als mechanische Störung beurteilt, und der Drucker stoppt).

## 2. BESCHREIBUNG UND BEZEICHNUNG DER GERÄTETEILE

### Frontabdeckung

Schützt den Drucker vor Staub, und reduziert das Betriebsgeräusch. Nicht die Frontabdeckung während des Druckens öffnen (dies wird als mechanische Störung beurteilt, und der Drucker stoppt).

### Rückabdeckung

Schützt den Drucker vor Staub, und reduziert das Betriebsgeräusch.

### Bedienfeld

Hat zwei Bedienungstasten und drei Anzeigen zur Anzeige des Druckerzustands.

### Netzschalter

### Netz kabel

Zum Anschluß an eine Netzbuchse. Der Stecker ist je nach Bestimmungsland unterschiedlich ausgelegt.

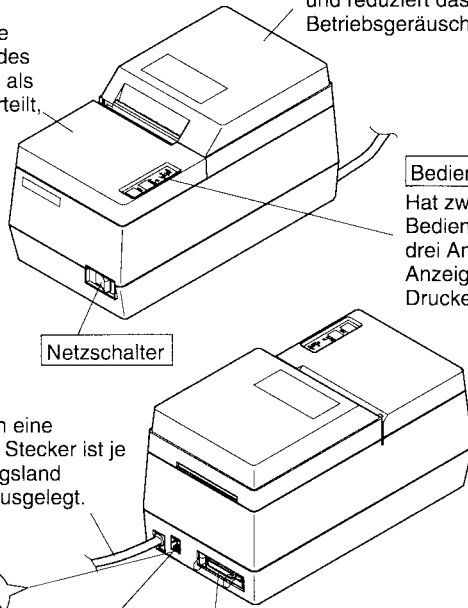


### Peripheriegerät-Steueranschluß

Zum Anschluß an Peripheriegeräte wie Registrierkassen etc.  
Nicht zum Anschluß an ein Telefon!

### Schnittstellenbuchse

Zum Anschluß des Druckers an den Hostcomputer.

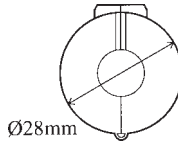


**Abb. 2-1 Außenansicht des Druckers (SP317)**

# 3. INSTALLATION DES FERRITKERNS

**HINWEIS:** Wenden Sie bei der folgenden Montage besondere Vorsicht an.

■ Mit dem Drucker werden zwei Ferrit Störfilter mitgeliefert. Das eine Filter ist für die Montage an dem Interfacekabel vorgesehen, während das andere für das Treiberkabel der Kasse vorgesehen ist.



■ Der Ferritkern ist normalerweise so verpackt, daß das Gehäuse geöffnet ist, wie das in der Abbildung 3-2 dargestellt ist. Sollte der Ferritkern geschlossen sein, öffnen Sie ihn, indem Sie die Plastiklasche mit einem Schraubenzieher oder ähnlichem Werkzeug vom Ferritkern abheben (siehe Abbildung 3-1). Wenden Sie dabei besondere Vorsicht an, um weder den Ferritkern, noch die Plastiklasche zu beschädigen.

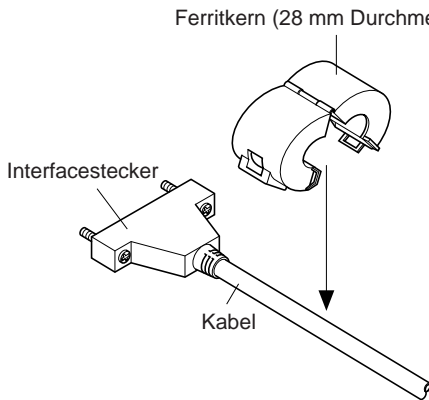


Abb. 3-2

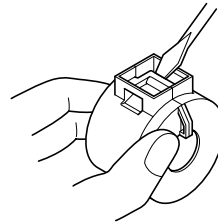
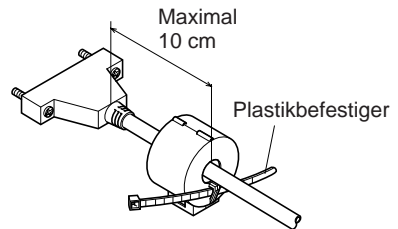
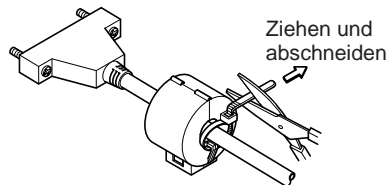


Abb. 3-1



Ziehen Sie den Plastikbefestiger durch das Gehäuse des Ferritkerns.

Abb. 3-3



Legen Sie den Plastikbefestiger um das Kabel und ziehen Sie ihn fest. Schneiden Sie das überschüssige Ende mit einer Schere ab.

Abb. 3-4

## Montage des Ferritkerns auf dem Interfacekabel

- Legen Sie den Ferritkern, wie in der Abbildung 3-2 gezeigt, um das Interfacekabel. Seien Sie bei der Montage besonders vorsichtig, damit weder das Gehäuse des Ferritkerns noch das Interfacekabel beschädigt werden. Der Ferritkern sollte mit dem Plastikbefestiger an seinem Platz sicher befestigt sein, wie in den Abbildungen 2-2 und 3-4 dargestellt.

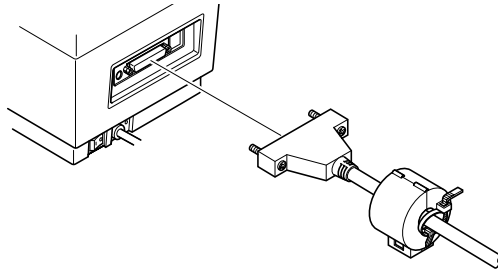


Abb. 3-5

## Montage des Ferritkerns auf dem Treiberkabel der Kasse

- Den Ferritkern auf das Kassentreiberkabel klemmen, und das Kabel so mit einer Schleife befestigen, wie in der Abbildung 3-2 gezeigt.
  - Beim Installieren des Ferritkerns darauf achten, das Kabel nicht zu beschädigen.
  - Der Ferritkern soll fest mit dem mitgelieferten Plastikhalterungsband befestigt werden, wie in der Abbildung gezeigt 3-3 und 3-4 gezeigt.
  - Nicht vergessen, das Kabel mit Schleife zu verlegen.

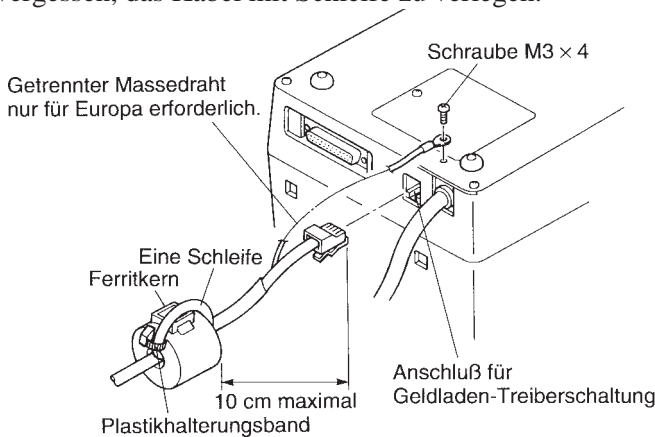


Abb. 3-6

## 4. ANSCHLUSS DES SCHNITTSTELLENKABELS

### 4-1. Seriellles Schnittstellenkabel

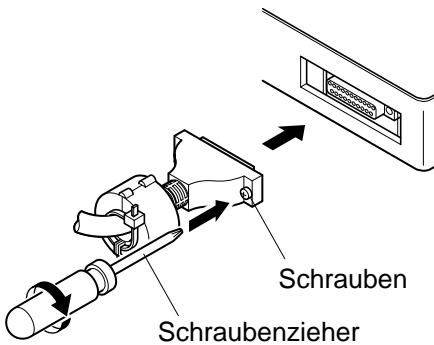


Abb. 4-1 Anschließen des seriellen Schnittstellenkabels

- ① Schalten Sie sowohl den Hostcomputer als auch den Drucker aus.
- ② Stecken Sie den Stecker des Schnittstellenkabels in die entsprechenden Buchsen am Drucker und am Hostcomputer ein.
- ③ Ziehen Sie die Schrauben an den Steckern fest.

### 4-2. Paralleles Schnittstellenkabel

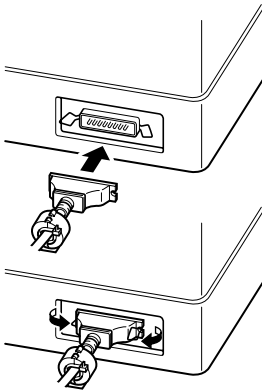


Abb. 4-2 Anschließen des parallelen Schnittstellenkabels

- ① Schalten Sie sowohl den Hostcomputer als auch den Drucker aus.
- ② Stecken Sie einen Stecker des Schnittstellenkabels in die parallele Schnittstellenbuchse am Drucker, und klemmen Sie ihn mit den Haltebügel fest, wie in der Abbildung 4-2 gezeigt.
- ③ Stecken Sie den anderen Stecker des Schnittstellenkabels in die parallele Schnittstellenbuchse am Hostcomputer, und klemmen Sie ihn mit den Haltebügel fest.

# INDICE

1. DISIMBALLAGGIO E INSTALLAZIONE .....	20
1-1. Disimballaggio .....	20
1-2. Note sul maneggio .....	20
2. IDENTIFICAZIONE DELLE PARTI E NOMENCLATURA .....	21
3. INSTALLAZIONE DEL NUCLEO IN FERRITE .....	22
4. COLLEGAMENTO DEL CAVO INTERFACCIA .....	24
4-1. Cavo interfaccia seriale .....	24
4-2. Cavo interfaccia parallelo .....	24
APPENDICE .....	25

*L'Appendice appare solo nella sezione in inglese di questo manuale.*

# 1. DISIMBALLAGGIO E INSTALLAZIONE

## 1-1. Disimballaggio

Dopo aver disimballato l'unità, controllare che tutti gli accessori siano inclusi nella confezione.

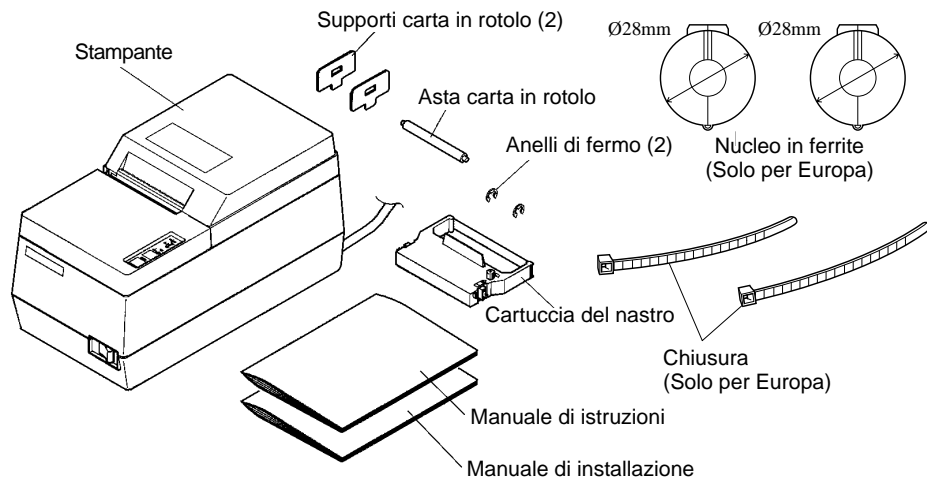


Fig. 1-1 Disimballaggio (SP317)

## 1-2. Note sul maneggio

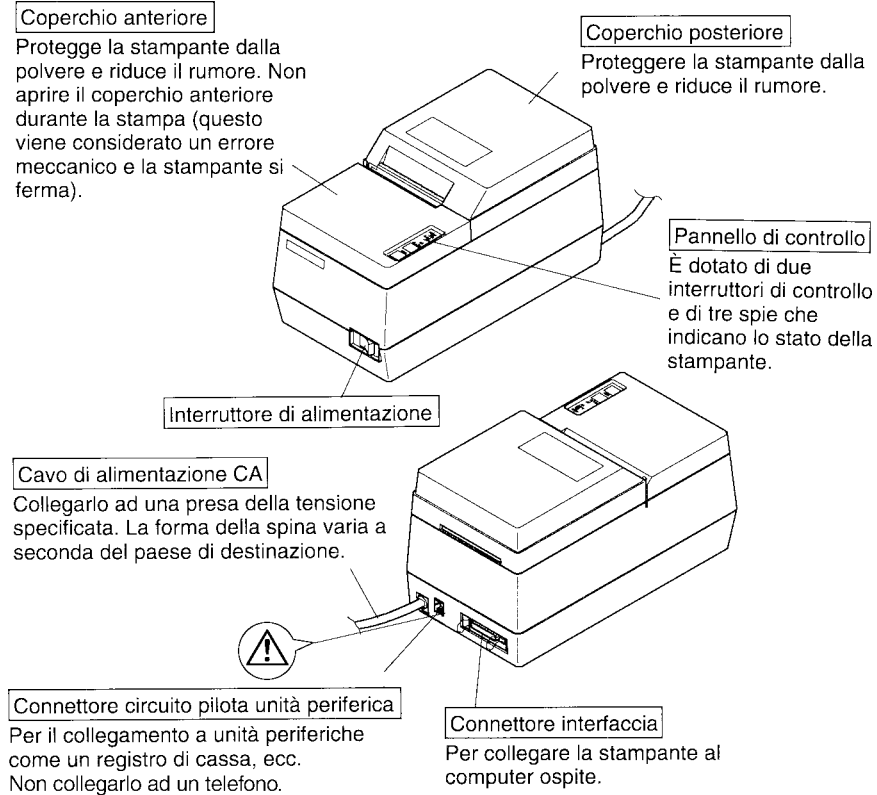
1. Installare l'unità su un appoggio o un tavolo dalla superficie piana e regolare.
2. Non collegare la spina del cavo di alimentazione CA ad una presa cui sono collegati altri dispositivi che generano disturbi elettrici (come motori elettrici, ecc.).

### **IMPORTANTE!**

Installare la stampante vicino ad una presa di corrente facilmente accessibile.

3. Fare attenzione a non lasciar cadere graffette, spilli o altri oggetti estranei nell'unità perché possono causare malfunzionamenti della stampante.
4. Quando si pulisce la superficie esterna dell'unità, togliere lo sporco, materiali estranei, ecc. con un panno morbido inumidito con detergente neutro.
5. Non tentare di stampare quando la carta o la cartuccia del nastro non sono inserite nella stampante perché tale azione può danneggiare la testina di stampa.
6. Usare solo carta in rotolo che non è incollata al supporto centrale.
7. Non aprire il coperchio anteriore durante la stampa (questo viene considerato un errore meccanico e la stampante si ferma).

## 2. IDENTIFICAZIONE DELLE PARTIE NOMENCLATURA

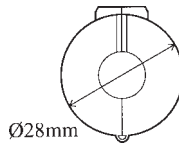


**Fig. 2-1 Vista esterna della stampante (SP317)**

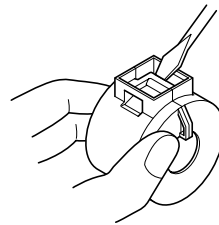
### 3. INSTALLAZIONE DEL NUCLEO IN FERRITE

**NOTA:** Prestare particolare attenzione durante l'esecuzione delle procedure indicate di seguito.

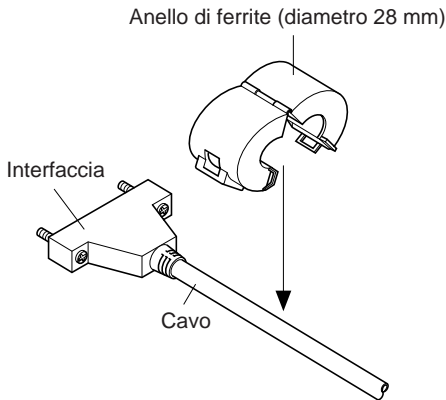
■ Insieme alla stampante vengono forniti in dotazione due anelli di ferrite antidisturbi. Uno va fissato sul cavo d'interfaccia seriale, mentre l'altro serve per il cavo di collegamento del registratore di cassa.



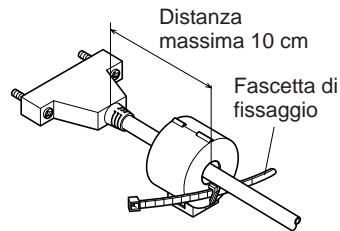
■ L'anello di ferrite è normalmente confezionato aperto, come mostrato in Fig. 3-2. Se si trova uno degli anelli di ferrite chiuso, aprirlo utilizzando un oggetto appuntito per far leva sul dispositivo di chiusura di plastica dell'anello di ferrite (Fig. 3-1). Fare attenzione a non danneggiare il nucleo di ferrite o il dispositivo di chiusura di plastica.



**Fig. 3-1**

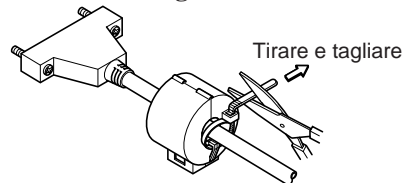


**Fig. 3-2**



Far passare la fascetta di fissaggio attraverso l'anello di ferrite.

**Fig. 3-3**



Far passare la fascetta di fissaggio intorno al cavo e bloccarla. Tagliare la parte in eccesso con delle forbici.

**Fig. 3-4**

## Come installare l'anello di ferrite del cavo d'interfaccia

- Fissare l'anello di ferrite sul cavo d'interfaccia come mostrato in Fig. 3-2. Fare attenzione a non danneggiare il cavo d'interfaccia quando si installa l'anello di ferrite. L'anello di ferrite va saldamente bloccato in posizione con la fascetta di fissaggio fornita in dotazione, come mostrato nelle Fig. 3-3 e 3-4.

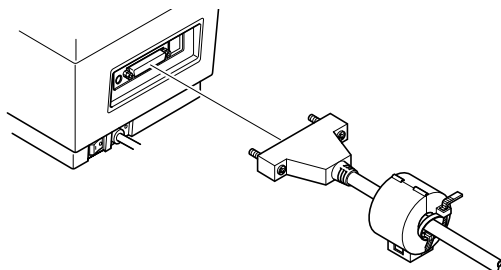


Fig. 3-5

## Come installare l'anello di ferrite del cavo di collegamento del registratore di cassetta

- Fissare il nucleo in ferrite al cavo pilota registro di cassetta, avvolgendo il cavo come mostrato nella Fig. 3-2.
- Quando si installa il nucleo in ferrite, fare attenzione a non danneggiare il cavo.
- Il nucleo in ferrite deve essere ancorato saldamente in posizione con il fermo in dotazione, come mostrato nella Fig. 3-3 e Fig. 3-4.
- Non dimenticare di avvolgere il cavo.

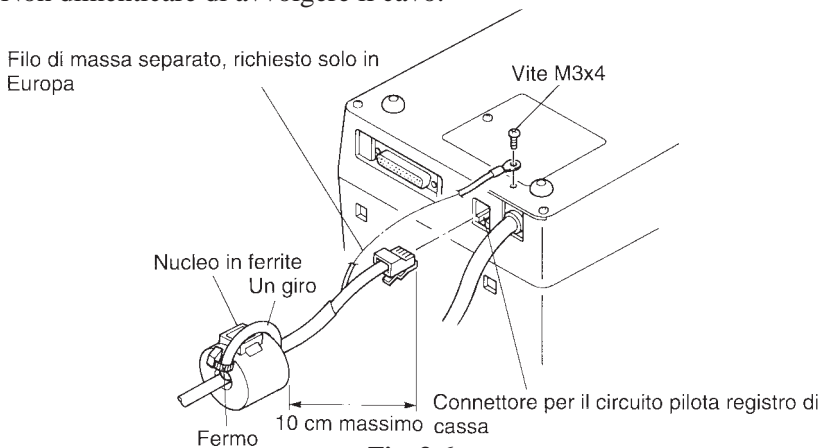


Fig. 3-6

## 4. COLLEGAMENTO DEL CAVO INTERFACCIA

### 4-1. Cavo interfaccia seriale

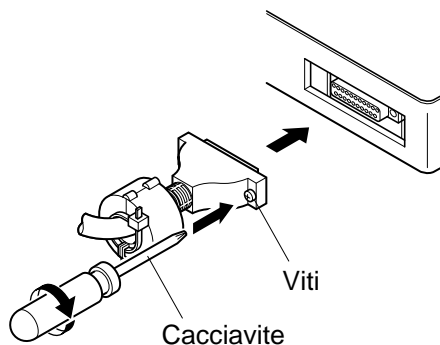


Fig. 4-1 Collegamento del cavo interfaccia seriale

- ① Spegnerne sia il computer ospite che la stampante.
- ② Inserire il connettore del cavo interfaccia nel connettore sulla stampante e l'altro capo del cavo interfaccia nel connettore sul computer.
- ③ Serrare le viti dei connettori.

### 4-2. Cavo interfaccia parallelo

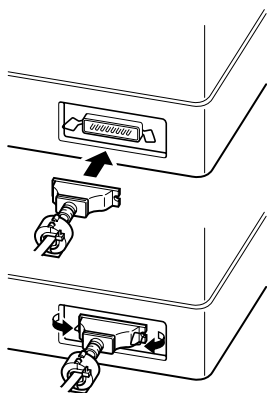


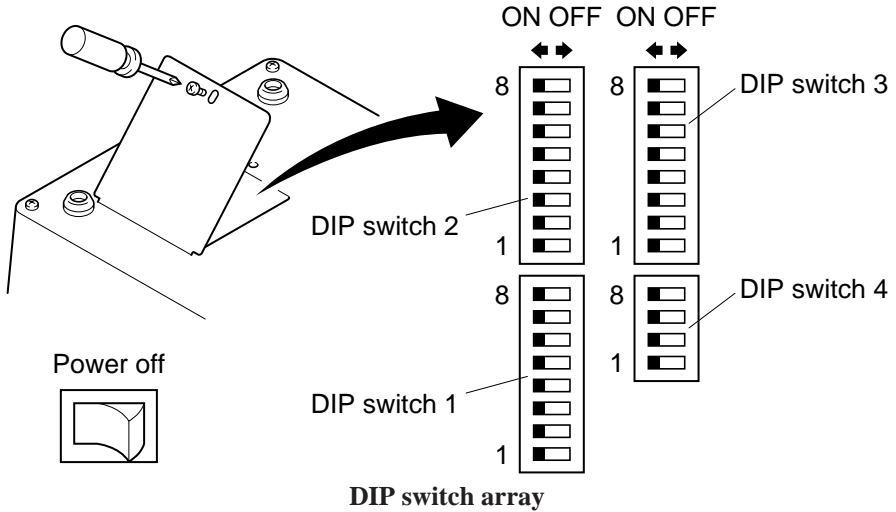
Fig. 4-2 Collegamento del cavo interfaccia parallelo

- ① Spegnerne sia il computer ospite che la stampante.
- ② Inserire un connettore del cavo interfaccia nel connettore sulla stampante e fissarlo con la morsa, come mostrato nella Fig. 4-2.
- ③ Inserire l'altro terminale del cavo interfaccia nel connettore sul computer e fissarlo con la morsa.

# APPENDIX

## DIP Switch Setting (Serial Interface)

Each of the switches in the DIP switch array is factory preset to the “ON” position. Be sure to turn the power for both the printer and host computer off before changing the setting of the DIP switches.



### ■ DIP-SW 1

Switch	Function	ON	OFF	
1-1	(Not used)			
1-2				
1-3	Control code CR	Invalid	Valid	
1-4	When turning the power on.	DC1, DC 3 mode	Select	Deselect
		Addressable mode *1	Deselect	Select
1-5	Setting the paper feed length	1/6-inch	1/8-inch	
1-6	Setting the buffer size	1 K-bytes	256 bytes	
1-7	(Not used)			
1-8	Paper out detection function	Valid	Invalid	

\*1 The addressable mode is valid only when the optional RS-422A serial interface is mounted.

## ■ DIP-SW 2

Switch	Function	ON	OFF
2-1	Character code table	See table below.	
2-2			
2-3	Setting the paper width	See table below.	
2-4			
2-5	(Not used)		
2-6	International character set	See table below.	
2-7			
2-8			

### Character code table (switches 2-1, 2-2)

Switch	U.S.A. & Europe	IBM #1	IBM #2	Japan
2-1	ON	OFF	ON	OFF
2-2	ON	ON	OFF	OFF

### Paper width setting (switches 2-3, 2-4)

Switch	3.0 or 3.25 inches		2.25 inches	
	2-3	ON	OFF	ON
2-4	ON	ON	OFF	OFF

### International character set (Switches 2-6, 2-7 and 2-8)

Switch	U.S.A.	France	Germany	England	Denmark	Sweden	Italy	Spain
2-6	ON	OFF	ON	OFF	ON	OFF	ON	OFF
2-7	ON	ON	OFF	OFF	ON	ON	OFF	OFF
2-8	ON	ON	ON	ON	OFF	OFF	OFF	OFF

■ DIP-SW 3

Switch	Function	ON	OFF
3-1	Data transmission rate	See table below.	
3-2			
3-3			
3-4	Auto cutting control mode (SP347)	Valid	Invalid
3-5	Handshake	DTR mode	X-ON/X-OFF mode
3-6	Data word length	8-data bit	7-data bit
3-7	Vertical parity check	No parity check	Parity check
3-8	Parity	Odd parity	Even parity

Data transmission rate (baud rate)

Baud rate	3-1	3-2	3-3
150 bps	OFF	OFF	OFF
300 bps	OFF	OFF	ON
600 bps	OFF	ON	OFF
1200 bps	OFF	ON	ON
2400 bps	ON	OFF	OFF
4800 bps	ON	OFF	ON
19200 bps *2	ON	ON	OFF
9600 bps	ON	ON	ON

\*2 This setting cannot be used with a 20 mA current loop.

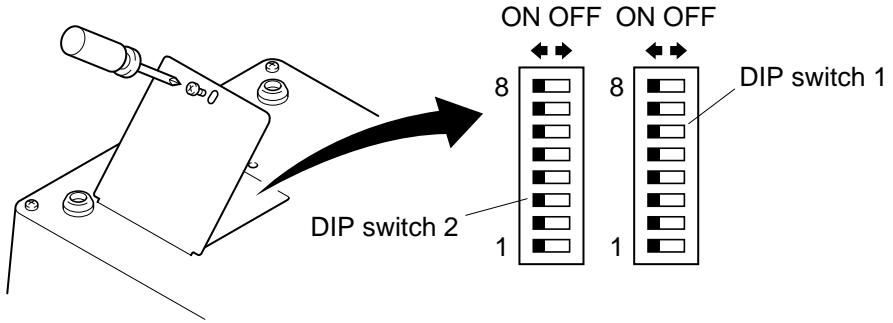
■ DIP SW 4

Function Switch	DC1, DC3	Addressable mode *3														DC1, DC3
	invalid mode	#1	#2	#3	#4	#5	#6	#7	#8	#9	#10	#11	#12	#13	#14	valid mode
4-1	ON	OFF	ON	OFF	ON	OFF	ON	OFF	ON	OFF	ON	OFF	ON	OFF	ON	OFF
4-2	ON	ON	OFF	OFF	ON	ON	OFF	OFF	ON	ON	OFF	OFF	ON	ON	OFF	OFF
4-3	ON	ON	ON	ON	OFF	OFF	OFF	OFF	ON	ON	ON	ON	OFF	OFF	OFF	OFF
4-4	ON	ON	ON	ON	ON	ON	ON	ON	OFF	OFF	OFF	OFF	OFF	OFF	OFF	OFF

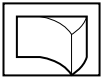
\*3 The addressable mode is valid only when an optional RS-422A serial interface is mounted.

## DIP Switch Setting (Parallel Interface)

Each of the switches in the DIP switch array is factory preset to the “ON” position. Be sure to turn the power for both the printer and host computer off before changing the setting of the DIP switches.



Power off



DIP switch array

### ■ DIP-SW 1

Switch	Function	ON	OFF
1-1	(Not used)		
1-2			
1-3	Control code CR	Invalid	Valid
1-4	Auto cutter (only SP347)	Valid	Invalid
1-5	Setting the paper feed length	1/6-inch	1/8-inch
1-6	Setting the buffer size	1 K-bytes	2-lines
1-7	(Not used)		
1-8	Paper out detection function	Valid	Invalid

■ DIP-SW 2

Switch	Function	ON	OFF
2-1	Character code table		
2-2	(See table below)		
2-3	(Not used)		
2-4	Setting the paper width	3.25 or 3.0-inch	2.25-inch
2-5	(Not used)		
2-6	International character set (See table below)		
2-7			
2-8			

Character code table (switches 2-1, 2-2)

Switch	U.S.A. & Europe	IBM #1	IBM #2	Japan
2-1	ON	OFF	ON	OFF
2-2	ON	ON	OFF	OFF

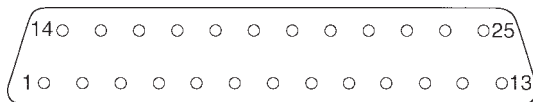
International character set (Switches 2-6, 2-7 and 2-8)

Switch	U.S.A.	France	Germany	England	Denmark	Sweden	Italy	Spain
2-6	ON	OFF	ON	OFF	ON	OFF	ON	OFF
2-7	ON	ON	OFF	OFF	ON	ON	OFF	OFF
2-8	ON	ON	ON	ON	OFF	OFF	OFF	OFF

# Connectors and Signals (Serial Interface)

## RS-232C

Pin no.	Signal name	I/O direction	Function
1	F-GND	—	Frame ground
2	TXD	OUT	Transmitted data
3	RXD	IN	Received data
4	RTS	OUT	Data transmission request signal. This is always “SPACE” when the printer is turned on.
5	CTS	IN	This signal changes to “SPACE” when host computer is ready to transmit data. (In this instance, the printer does not check this signal.)
6	N/C		Not connected
7	S-GND	—	Signal ground
8	N/C		Not connected
9-10	N/C		This pin is used when using the optional interface board.
11	RCH	OUT	This signal changes to “SPACE” when the printer is ready to receive data. (The signal line is same as pin 20.)
12	N/C		Not connected.
13	S-GND	—	Signal ground
14	FAULT	OUT	When a printer error occurs (such as paper out, mechanical error, etc.), this signal is set to “MARK”.
15	Multi-printer TXD	OUT	Diode coupled TXD
16	Multi-printer DTR	OUT	Diode coupled DTR
17 to 19	N/C		This pin is used when using the optional interface board.
20	DTR	OUT	Data terminal ready signal. When the printer is ready to receive data, this signal changes to “SPACE”.
21-22	N/C		Not connected
23 to 25	N/C		This pin is used when using the optional interface board.



**Serial interface connector**

## 20 mA current loop (option)

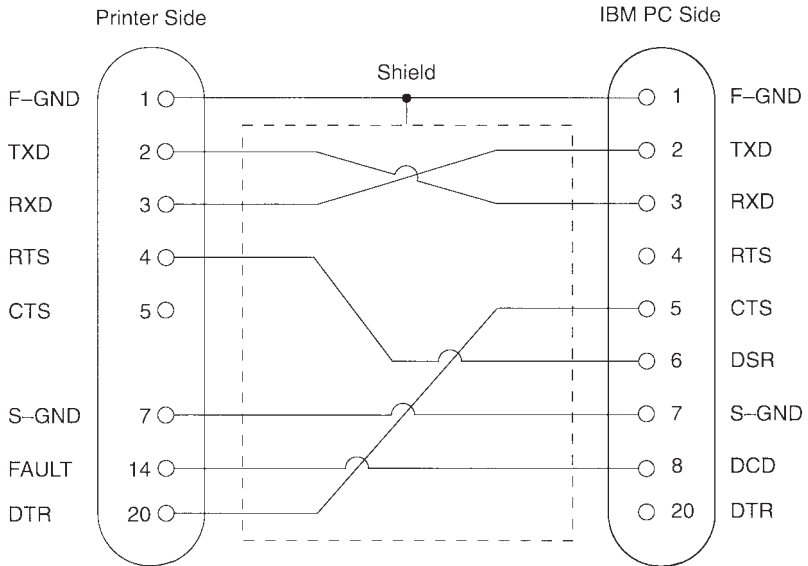
Pin no.	Signal name	I/O direction	Function
9	TTY TXDR	—	Indicates the ground side of the data signal of 20 mA loop current.
10	TTY TXD	OUT	Transmitted data of 20 mA current loop.
17	TTY TXDR	—	Indicates the ground side of the data signal of 20 mA loop current.
18	TTY RXDR	—	Indicates the ground side of the data signal of 20 mA loop current.
19	TTY RXD	IN	Received data of 20 mA current loop.
23	TTY RXDR	—	Indicates the ground side of the data signal at 20mA loop current.
24	TTY TXD	OUT	Transmission data of 20 mA current loop.
25	TTY RXD	IN	Reception data of 20 mA current loop.

## RS-422A (option)

Pin no.	Signal name	I/O direction	Function
9	SD (+)	OUT	Transmitted data
10	SD (-)	OUT	Transmitted data
17	RD (+)	IN	Received data
18	RD (-)	IN	Received data
19	CS (+)	IN	When the host computer is set to standby for data transmission, this signal changes to "SPACE". (In this instance, the printer does not check the signal.)
23	CS (-)	IN	When the host computer is set to standby for data transmission, this signal changes to "SPACE". (In this instance, the printer does not check the signal.)
24	RS (+)	OUT	Data transmission request signal. When the printer is ready to receive data, this signal changes to "SPACE".
25	RS (-)	OUT	Data transmission request signal. When the printer is ready to receive data, this signal changes to "SPACE".

## Interface Connections (Serial Interface)

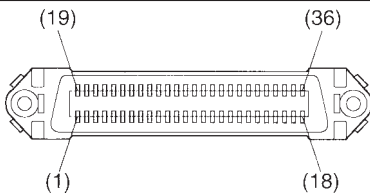
The following is a basic example of interface connections. (For interface connections, refer to the specifications for the respective interface.) An IBM PC type serial port is shown in below.



**Example of interface connections for an IBM PC**

## Connectors and Signals (Parallel Interface)

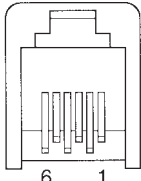
Pin No.	Signal Name	IN/OUT	Function
1	STROBE	IN	Signals when data is ready to be read. Signal goes from HIGH to LOW (for at least 0.5 microsec.) when the data is available.
2-9	DATA1-8	IN	These signals provide the information of the first to eighth bits of parallel data. Each signal is at HIGH level for a logical 1 and at a LOW level for a logical 0.
10	ACK	OUT	A 9 microsecond LOW pulse acknowledges receipt of the data.
11	BUSY	OUT	When this signal goes to LOW, the printer is ready to accept data. When the printer is in one of the conditions below, "HIGH" is set. 1. Data is being entered. 2. Off line. 3. Error condition.
12	PAPER OUT	OUT	This signal is normally LOW. It will go to HIGH if the printer runs out of paper.
13	SELECTED	OUT	This signal is HIGH when the printer is online.
14-15	N/C		Unused
16	SIGNAL GND		Signal ground.
17	CHASSIS GND		Chassis ground, isolated from logic ground.
18	+5VDC		+5VDC (Max 50 mA)
19-30	GND		Twisted pair return the signal to ground level.
31	RESET	IN	When this signal goes to LOW, the printer is reset to its power-on condition.
32	ERROR	OUT	This signal is normally HIGH. This signal goes to LOW to signal that the printer cannot print due to an error condition.
33	EXT GND		External ground.
34	COMPULSION	OUT	Compulsion signal
35	N/C	-	Unused.
36	-	-	This signal is normally set to HIGH on the printer side.



This connector mates with an Amphenol 57-30360 connector

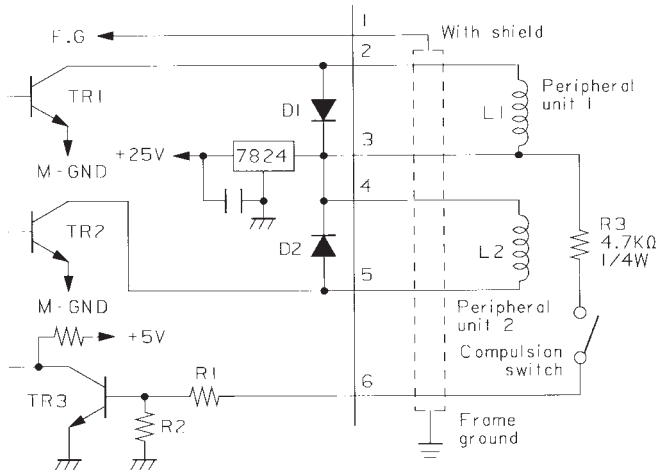
**Parallel interface connector (printer side)**

# Peripheral Unit Drive Circuit



6-P modular jack connector

[Drive output 24V, max. 1.0 A]



Drive circuit

AC power cable:

Approx. 155 cm long

# MEMO



**ELECTRONIC PRODUCTS DIVISION  
STAR MICRONICS CO., LTD.**

536 Nanatsushinnya, Shimizu, Shizuoka,  
424-0066 Japan

Tel: 0543-47-0112, Fax: 0543-48-5013

Please access the following URL  
[http://www.star-micronics.co.jp/service/sp\\_sup\\_e.htm](http://www.star-micronics.co.jp/service/sp_sup_e.htm)  
for the latest revision of the manual.

**OVERSEAS SUBSIDIARY COMPANIES  
STAR MICRONICS AMERICA, INC.**

1150 King Georges Post Road, Edison,  
NJ 08837-3729 U.S.A.

Tel: 732-623-5555, Fax: 732-623-5590

**STAR MICRONICS U.K. LTD.**

Star House, Peregrine Business Park, Gomm Road,  
High Wycombe, Bucks, HP13 7DL, U.K.

Tel: 01494-471111, Fax: 01494-473333