

Barcode Blaster[™]

Desktop bar code printer



User's Guide

CSIPN:10-00-0209

REV. D

February 18, 1999

Copyright © 1999 by Axiohm, Inc.

Barcode Blaster™ is a trademark of Axiohm, Inc. Microsoft® and Windows™ are trademarks of Microsoft Corporation. Other product and corporate names used in this publication may be trademarks or registered trademarks of other companies, and are used only for explanation and to their owner's benefit, without intent to infringe.

All information in this manual is subject to change without notice, and does not represent a commitment on the part of Axiohm, Inc. No part of this manual may be reproduced for any purpose or in any form, including electronic storage and retrieval, without the express permission of Axiohm, Inc.

FCC Notice

This equipment has been tested and been found to comply with the limits for a Class A digital device, pursuant to Part 15 of the FCC Rules. These limits are designed to provide reasonable protection against harmful interference when the equipment is operated in a commercial environment. This equipment generates, uses, and can radiate radio frequency energy and, if not installed and used in accordance with the instruction manual, may cause harmful interference to radio communications. Operation of this equipment in a residential area is likely to cause harmful interference in which case the user will be required to correct the interference at his own expense.

CE Notice

Warning

This is a Class A product. In a domestic environment this product may cause radio interference in which case the user may be required to take adequate measures.

Note:

This manual does not contain printer programming information. Windows printer drivers and a WYSIWYG label design package are supplied with every Barcode Blaster. The supplied software lets users design and print labels from within Microsoft Windows 95, NT, or 3.1/3.11, without programming. Information on this software is on page 16.

For those who want to control their printer directly, a file called PROGGDE.HLP on the drivers disk contains printer programming information in Windows Help format. You can load and read this file using WINHELP.EXE provided with Microsoft Windows 3.1 or above. Please refer to your Windows documentation if you do not know how to do this.

If you need programming information and are not using Windows (or cannot read the Help file for any other reason), contact our Technical Support Services Organization for assistance. Contact information is on page 15.

Contents

PRINTER SPECIFICATIONS	2
COMMUNICATIONS PORTS	3
Standard printer cables	3
Serial port communication parameters	3
CONTROLS, INDICATORS, AND CONNECTIONS	5
SETUP	5
Printer power connection	5
Loading labels or tags	6
Loading thermal transfer ribbon	6
Selecting the print mode and index method	8
USING THE PRINTER	9
Printing a self-test label	9
Feeding blank labels	9
Sending data to the printer	9
Printing labels	10
Controlling the printer using direct commands	10
ROUTINE MAINTENANCE	11
WHAT TO DO IF...	12
POWER indicator is not lit	12
READY indicator is not lit	12
READY indicator is red	13
Self-test label will not print	13
Labels will not feed	13
Host stops responding or displays “printer not ready” message	13
Labels feed continuously	14
Print quality is poor	14
TECHNICAL SUPPORT	15
Contact information	15
APPENDIX A: SUPPLIED SOFTWARE	16

PRINTER SPECIFICATIONS

Model	BD242005	BD422005	BT242004	BT422004	
Print method ¹	DT	DT	DT+TT	DT+TT	
Pitch (DPI) ²	203/101	203/101	203/101	203/101	
Max media width (inches/mm)	2.4 61	4.25 108	2.4 61	4.25 108	
Min. media width (inches/mm)	1 25	2 50	1 25	2 50	
Max print width (inches/mm)	2.2 56	4.1 104	2.2 56	4.1 104	
Max print length (inches/mm) ³	11.1 282	6.0 152	11.1 282	6.0 152	
Print speed (IPS) ²	5/3/1.5	5/3/1.5	4/2.5	4/2.5	
Size (inches/mm)					
Height	6.1/155	6.1/155	6.1/155	6.1/155	
Width	4.7/120	6.8/173	5.0/127	6.8/173	
Depth	9.4/239	9.4/239	9.4/239	9.4/239	
Weight (lbs./kg) ⁴	3.1/1.40	3.9/1.77	4.0/1.81	4.5/2.04	

Common Specifications

Installed RAM:	128 kB total, 126 kB user accessible	Graphics:	PCX, BMP file support plus CSI raster format
Communications:	RS232 serial and/or Centronics parallel	Bar codes:	UPCA/E/E1, ADD2/5, EAN8/13/128, Code39, I2OF5, Code128A/B/C, CODABAR, Plessey, MSI, MSI1, PDF417, MaxiCode, Code16K
Max. media roll diameter:	4.7" 119mm	Bar code rotation:	0 and 90 deg. CW
Indexing methods:	Black bar, Gap	Power:	AC power transformer (supplied), output 19.6 VAC. Specify 120 or 230 VAC input when ordering
Min. form length:	0.25" 6.35mm	Environmental:	5 to 40 C operating -20 to 50 C storage 25 to 85% non-condensing relative humidity
Min. label repeat distance:	0.375" 9.5mm		
Text fonts:	3X5, 5X7, 8X8, 9X12, 12X16, 18X23, 24X31, UltraFont A, B, and C, CGI Trumvirate in 7 sizes		
Text rotation:	0, 90, 180, 270 deg. CW		

Notes:

1. DT = Direct Thermal, TT = Thermal Transfer.
2. Print pitch and speed values shown are software selectable.
3. Maximum print length is at maximum width and pitch, default memory settings, with standard RAM.
4. Specified weight is without media.

COMMUNICATIONS PORTS

Barcode Blaster printers may be equipped with Centronics parallel and/or RS232 serial ports, wired as shown below.

Serial input connector (DB9S)

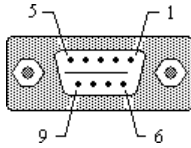

<u>Pin #</u>	<u>Description</u>
2	RXD (printer data input)
3	TXD (printer data output)
5	Ground (-)
7	RTS (printer busy)
8	CTS

Parallel input connector (Centronics 36 pin)

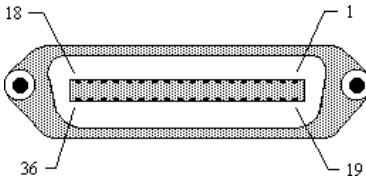

<u>Pin #</u>	<u>Description</u>
1	Strobe
2 - 9	Data bits 0 - 7
10	Acknowledge
11	Busy
12	Out of paper
13	+5VDC
17	Chassis ground
31	Reset
32	+5VDC
16, 33, 19-30	Signal ground

Standard printer cables

The following standard cables are available for Barcode Blaster:

Centronics parallel cable: Order CSI P/N 61-00-0002

RS-232 cable, DB9 to DB9: Order CSI P/N 90-88-0079

RS-232 cable, DB9 to DB25: Order CSI P/N 90-88-0078

Serial port communication parameters

Barcode Blaster printers are configured as DTE equipment, and use RTS/CTS handshaking or XON/XOFF protocol (control characters are DC1 and DC3). The serial port supports the following parameters:

Speed:	600, 1200, 2400, 4800, 9600, 14400, 19200, 38400, 57600
Parity:	Odd, Even, or None
Word length:	7 or 8 bits
Stop bits:	1 or 2 bits
Default parameters:	9600 baud, no parity, 8 data bits, 1 stop bit

Note:

Barcode Blaster printers require a “null modem” when connected to another DTE device (i.e., a personal computer). The serial cables listed above are wired in a null modem configuration. Other cables may require an external null modem adapter.

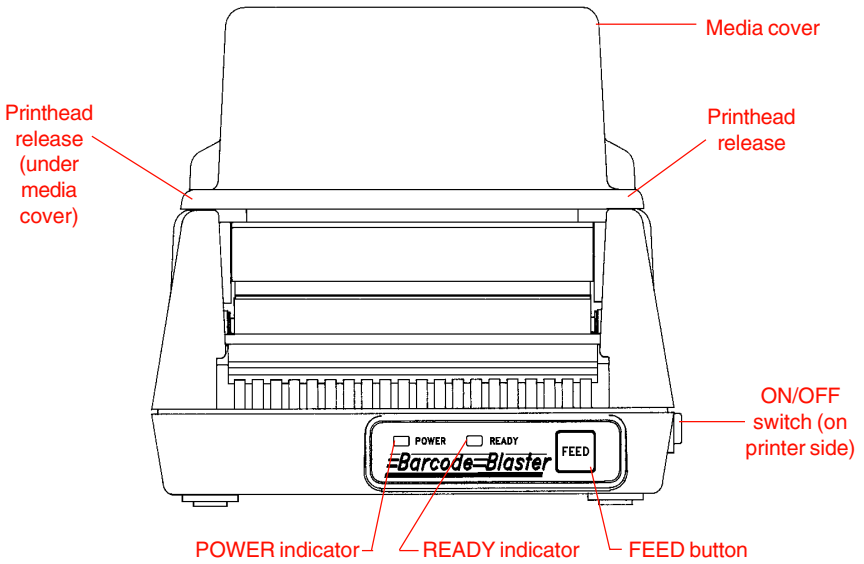

Note:

These figures show the 4.25" DT printer. Other models are similar.

Figure 1. Printer front view

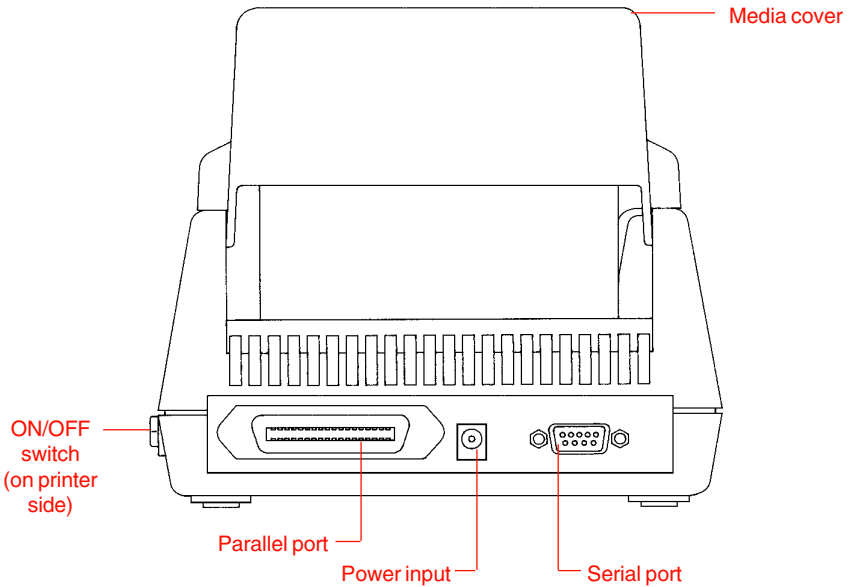

Figure 2. Printer rear view

CONTROLS, INDICATORS, AND CONNECTIONS

Device name	Primary function	Use
ON/OFF switch	Controls printer power	ON - for normal operation OFF - for storage
FEED button	Advances print media	PRESS - to advance media PRESS and HOLD while turning printer ON - to print test label PRESS to pause printing during batch mode operation
POWER indicator	Glowes when printer power is ON	OFF - printer power off GREEN - printer power on
READY indicator	Shows printer status	GREEN - Printer ready for data OFF - Printer busy, or turned off RED - Printer error, or printer paused during batch mode operation
Power input	Connects to power supply	Connect to transformer provided with printer
Serial port	Data input	DB9 female connector for connection to host controller, RS-232 protocol
Parallel port	Data input	Centronics compatible connector for connection to host controller
Printhead release	Unlocks printhead	Push toward rear of printer to release printhead
Media cover	Protects print media	Lift to open Squeeze at hinge and lift to remove

SETUP

Printer power connection

1. Plug the output of the AC power supply provided with the printer into the circular connector on the printer rear panel.
2. Plug the supply into an AC outlet having the proper voltage.

Important!

The required AC voltage is marked on the power supply. Confirm that your AC voltage matches the power supply requirements. Do not use any power supply other than the one provided with the printer.

Loading labels or tags

1. Lift open or remove the printer media cover.
2. Press the two printhead releases back to unlock the printhead, then lift the printhead until it is fully raised.
3. Lift out the paper spindle.
4. Remove any print media or empty label core from the printer.

Note:

This is a good time to clean the printhead. See page 11 for printhead cleaning instructions.

5. Unwrap the new media, and unwind a few labels from the roll.
6. Insert the paper spindle in the media roll so that the paper guide's flat side faces the media right side and the media unwinds from the bottom of the roll toward the front of the printer. *The label imaging surface must face up as it passes under the printhead.*
7. Adjust the paper guide as required to allow room for the media.
8. While lowering the media roll into the paper tray, slip the free end of the media under the printhead.
9. Adjust the paper guide until the media is snug between the paper guide and the left side of the paper tray.
10. Lower the printhead and press it down firmly until it locks closed.
11. (Optional) close the media cover.
12. Confirm that the printer is turned ON. Press the FEED button to feed a label or to resume printing.

Loading thermal transfer ribbon

Thermal transfer printers must have a ribbon installed when printing thermal transfer labels or tags. Load ribbon as follows (see Figure 4):

1. Lift open or remove the printer media cover.
2. Unlock and raise the printhead as for loading labels or tags (step 2 in the previous section).
3. Two arms hold each ribbon core. The right arms can flex outward. Remove the old ribbon cores by pressing each flexible arm outward until the cores clear the support arms.

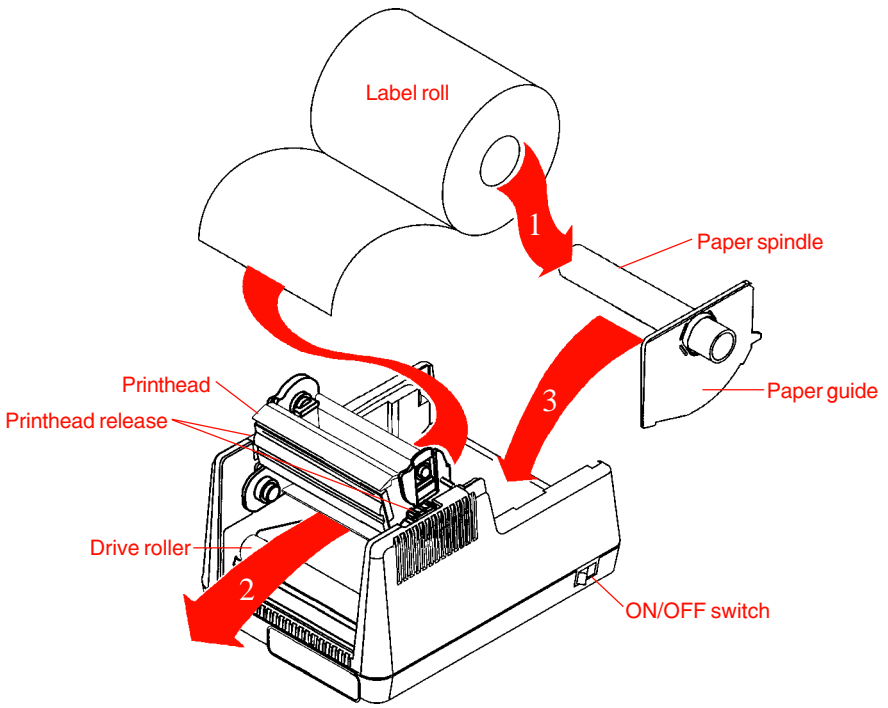

Figure 3. Loading labels

Note:

Printer is shown with media cover removed, for clarity.

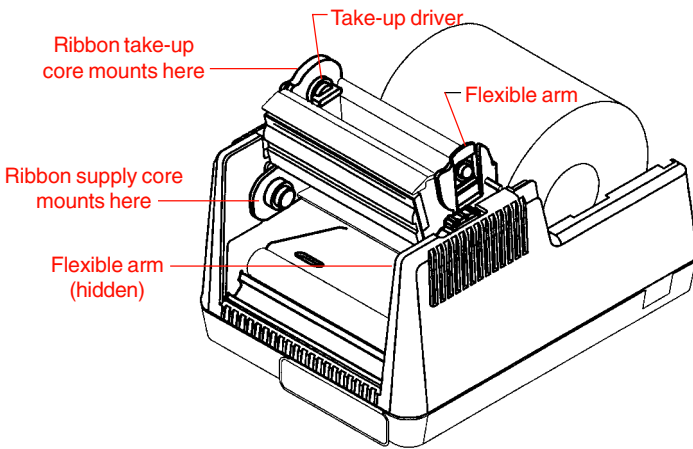

Figure 4. Thermal transfer mechanism

Note:

This is a good time to clean the printhead. See page 11 for printhead cleaning instructions.

4. Unwrap the new ribbon. Unwind the ribbon from the ribbon supply roll (the full roll) until you are past the end of the ribbon leader. Wind the ribbon leader and a few inches of black ribbon onto the empty ribbon take-up core.
5. The ribbon supply roll mounts in the bottom core holder. The take-up core mounts in the top core holder. The slotted end of the take-up core mates with the take-up driver on the left side of the thermal transfer mechanism. *The ribbon shiny side must face the printhead; its dull side must face the drive roller.*
6. Press the flexible arm on the bottom core holder outward and snap the ribbon supply core into place.
7. Turn the ribbon take-up core until its slotted end aligns correctly with the take-up driver, then press the core onto the driver.
8. Press the right end of the top core holder outward and snap the ribbon take-up core into place.
9. Lower the printhead and press it down firmly until it locks closed.
10. Confirm that the printer is turned ON. The printer will take up any ribbon slack when you close the printhead.

Note:

Thermal transfer printers can operate in direct thermal or thermal transfer mode, and must be set for the correct print mode for best results.

Selecting the print mode and index method

All Barcode Blaster printers can use black bar or gap indexing. Thermal transfer printers can print in thermal transfer and direct thermal mode. The printers must be set up for the proper print mode and index method for the currently loaded print media.

If you are using label printing software, the software should provide a means to set up these parameters. See your software documentation for details.

If you are writing your own software or controlling the printer using direct commands, you must use printer commands to set up the print mode and index method. Refer to the programming information provided in the PROGDE.HLP file for further information.

USING THE PRINTER

Printing a self-test label

Printing a self-test label checks the printer's overall operability. To run a self-test, confirm that the printer is loaded, connected to AC power, and turned OFF. Then:

1. Press and hold in the FEED button.
2. Turn the printer ON.
3. The printer should begin printing after a second or two. Release the FEED button after printing starts.
4. After the self-test label finishes printing, turn the printer OFF, wait a few seconds, then turn the printer back ON again.

Important!

The printer will be in hex dump mode after printing the self-test label. It cannot print normal labels in hex dump mode. The printer will return to normal operation after you turn it off and on once.

Feeding blank labels

To feed labels:

1. Confirm that the printer is ON.
2. Press and release the FEED button to feed a label. Press and hold in the FEED button to feed multiple labels.

Sending data to the printer

To print labels using data sent from a host computer or terminal:

1. Connect the host and printer serial or parallel ports together using a correctly wired interface cable (see page 3 for wiring information).
2. If you are using the serial port, confirm that the host and printer are using the same communications parameters.
3. Confirm that the printer is ON.
4. Send your data to the printer.

Printing labels

To print labels, the host computer sends commands to the printer via the serial or parallel communications port.

If you use a label printing software package, the computer and software control the entire printing process. You only need to set up the printer, start your label printing program, and follow its instructions. Contact the software supplier or manufacturer if you encounter difficulties when using commercial software.

Controlling the printer using direct commands

You can also produce labels by sending commands directly to the printer. Simple ASCII commands control the printer. You can write command files using any word processor that can output ASCII text.

Since printer programming is potentially complex, programming information is not provided here. A printer command reference and basic programming procedures are provided on the floppy disk packed with the printer. The file `PROGGDE.HLP` on the disk is a Microsoft Windows Help file, readable using `WINHELP.EXE` provided with Microsoft Windows 3.1 or above.

If you need programming information and are not using Windows (or cannot read the Help file for any other reason), contact our Technical Support Services Organization for assistance (please see page 15 for contact information).

ROUTINE MAINTENANCE

Cognitive printers need very little maintenance other than occasional cleaning. Clean the printer body as required, using a soft cloth moistened with a mild detergent cleaner.

We recommend cleaning the printhead when loading print media. Printhead cleaning is easy and fast:

1. Unlock and raise the printhead if it is not already raised.
2. If you are cleaning a thermal transfer printer with a ribbon installed, remove the ribbon take-up core and lay it in front of the printer.
3. Using a soft cloth moistened with 98% or 99% pure isopropyl or denatured alcohol, clean all dirt and label residue from the printhead, paying particular attention to the “burn line” (this is the thin black line near the front edge of the printhead).

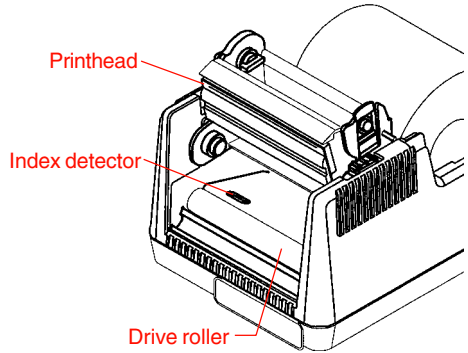

Figure 5. Printer opened for cleaning

Caution!

Do not clean the printhead or drive roller using abrasive or metallic objects, or ammonia-based cleaners or other harsh chemicals. These practices can cause serious damage.

4. If you removed the thermal transfer ribbon take-up core, reinstall it now.
5. Wipe the drive roller with the cleaning cloth. To reach all portions of the drive roller, confirm that the printer is ON. Press the FEED button, then clean the drive roller as it turns.

Caution!

Take care that the cleaning cloth does not become entangled with the ribbon mechanism or drive roller during this process.

6. Confirm that the index detector is unobstructed.
7. Resume the media loading procedure, or if there is already media in the printer, lower and lock the printhead.
8. Confirm that the printer is ON and resume normal operation.

WHAT TO DO IF...

Cognitive printers are very reliable, so printing problems are unlikely. If you do think you have a printer problem, proceed as follows:

1. Confirm that the printer has the right media installed, and that it is loaded correctly. See page 6 for media loading instructions.
2. Confirm that the printer is connected to its power supply and the supply is plugged into an AC outlet having the proper voltage.
3. Open the printhead and inspect the media path. Remove any obstructions, and clean the printhead and drive roller according to the instructions on page 11.
4. Press down firmly on the printhead to confirm that it is closed.
5. Confirm that the printer is turned ON and that the POWER and READY indicators are both glowing green.
6. Print a self-test label as described on page 9.
7. Press FEED to confirm that the printer will feed a label.
8. Review the common problems described in the following section.
9. If these steps do not correct the problem, contact your Cognitive dealer or our Technical Services Department. You will find Technical support contact information on page 15.

Note:

The information here assumes that you are using label printing software. If you are programming the printer, review the troubleshooting information in the PROGGDE.HLP file.

Common problems and their solutions

POWER indicator is not lit

Double-check the AC source and the power supply connections. If this does not correct the problem, the power supply may have a blown fuse. Contact our Technical Services Department for assistance.

READY indicator is not lit

Disconnect the cable between the printer and host, then turn the printer OFF and back ON. If the READY indicator remains dark, there may be a printer problem. If the READY indicator glows green with the host disconnected, suspect a host computer or cabling problem.

READY indicator is red

1. Press the FEED switch to make certain that the printer is not paused during a batch operation.
2. Confirm that the print media is not exhausted.

Self-test label will not print

1. If using a thermal transfer printer, confirm that the ribbon is loaded correctly. The ribbon dull side should face the drive roller.
2. If using a direct thermal printer, confirm that you have loaded direct thermal media.
3. Disconnect the cable between the printer and the host computer, turn the printer OFF, then try to print a self-test label again.

Labels will not feed

1. Confirm that the print media is loaded correctly.
2. Turn the printer OFF and back ON. Confirm that both printer status indicators glow green. Press the FEED button.
3. If the printer still does not feed, disconnect the communications cable and repeat step 2. If the printer feeds with the cable disconnected, suspect a problem with the host computer or cable.

Host stops responding or displays “printer not ready” message

1. Review your software setup, following the instructions provided with the software.
2. Confirm that the host-to-printer communication cable is connected and undamaged. If the printer is connected to the serial port on a personal computer or other DTE device, confirm that you are using a null modem cable or adapter.
3. If using the serial port, confirm that the host and printer are both using the same serial port parameters. The self-test label shows the current printer serial port parameters.
4. If using a communications switch between the host and printer, remove the switch and connect the printer directly to the host.
5. Turn the printer OFF, reset the host computer and software, turn the printer ON, and try printing again.

Labels feed continuously

1. Check that the print media is loaded correctly.
2. Confirm that the index setting (black bar or gap) in your software setup matches your print media.

Print quality is poor

1. Confirm that the print media is properly loaded, and there is no side-to-side motion of the paper as it feeds through the printer.
2. Check your software's print darkness and print speed settings. These settings may need adjustment for optimum results.
3. Try different print media. Old or inferior quality media will degrade print quality.
4. If using a thermal transfer printer:
 - A. Confirm that the ribbon is correctly loaded. Check that the ribbon cores are firmly seated on the support arms.
 - B. Press and hold in the FEED button to feed several labels. Confirm that the ribbon is not wrinkling. Occasional wrinkling is normal, but frequent wrinkling may indicate a defective ribbon.

TECHNICAL SUPPORT

Please contact your local dealer first for technical support. Your dealer is knowledgeable about Cognitive printers, printing software, and your unique system. Contact our Technical Support Services Department if you still need technical assistance after talking to your dealer.

If you must return any products to the factory, first obtain a returned material authorization number (RMA) from our Technical Support Services Department. When calling, *please* have your printer model number and serial number handy.

Contact information

General

If you aren't sure which department you need, contact us by mail or through one of our general numbers:

Mailing address Cognitive
691 Corporate Circle
Golden, CO 80401
USA

Telephone (303) 273-1400

Toll free (800) 525-2785

Fax (303) 273-1414

E-mail Info@cogsol.com

You can get immediate information on Cognitive products via the Internet:

Internet URL www.cogsol.com

Sales Department

Toll free (800) 525-2785

Fax (303) 278-9487

E-mail Sales@cogsol.com

Technical Support Services Department

Toll free (888) 715-7190

Fax (303) 590-0518

E-mail: techsup@cogsol.com

Hours of operation

We are open from 8 AM to 5 PM Mountain Time, Monday through Friday. Our Technical Support Services and Sales departments are open from 7 AM to 5 PM. For the fastest response, contact us during our normal working hours.

APPENDIX A: SUPPLIED SOFTWARE

Software is included with every Barcode Blaster printer for use with Microsoft Windows 95, Windows NT, Windows for Workgroups, or Windows 3.1/3.11. Two basic packages are provided:

- The Cognitive *Intellidriver*[™] lets you print labels with your Solus printer using virtually any Windows application.
- *LabelMagic*[™] is a full-featured WYSIWYG label layout and printing package specifically designed for use with Cognitive printers.

These software packages and a Blaster printer give Windows users an easy to use label printing solution with nothing else to buy.

Intellidriver installation and use

An automatic setup program, `SETUP.EXE`, is provided with the Intellidriver. Install the desired printer drivers by running `SETUP.EXE` from within Windows and following the displayed instructions. Restart your system after installing the Intellidriver.

After the drivers are installed, you can send data to your Barcode Blaster just like any other printer on your system: simply specify your printer model in the print dialog box of your Windows application. To print bar codes, enter bar code data using any text font, then highlight the information you want to print as a bar code and select the desired bar code font from your application's font menu. The driver will convert the text to an on-screen representation of a generic bar code.

On-line help for the Intellidriver is available from the printer setup window, which is accessible from the print dialog box of most Windows applications. Please refer to the on-line help and the `README.TXT` file on the Intellidriver disk for detailed operating instructions.

LabelMagic installation and use

An automatic installation program, `SETUP.EXE`, is provided on the LabelMagic installation disk. Install LabelMagic by running `SETUP.EXE` and following the displayed instructions. The installation program will copy the program files to your system and install program icons on your desktop and/or system Start Menu.

LabelMagic has a complete context-sensitive help system that describes all aspects of the program's use. You can access the help system by selecting **Help** from the program's main menu. Please refer to the help system and the `README.TXT` file on the LabelMagic installation disk for detailed operating instructions.