

Welch Allyn ® SCANTEAM® 2000 WEDGE

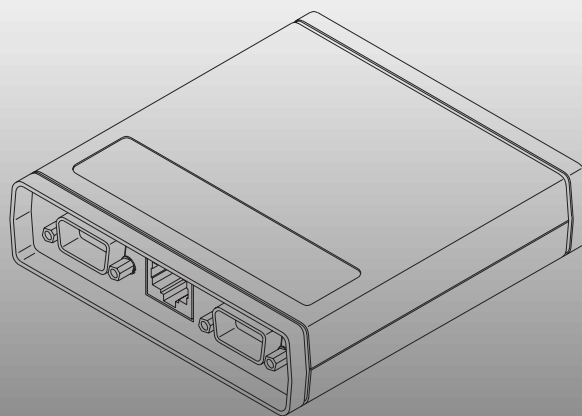

PROGRAMMING MENU



The SCANTEAM 2000 Programming Menu is used to program both the 2000/R(etail) and the 2000/C(ommerical) Decoders. Notations are included if the information applies only to the 2000/C or to the 2000/R.

The SAMPLE BAR CODES page (near the end of the programming menu) contains bar code symbols that you may use to verify that you have programmed your SCANTEAM 2000 correctly.

A chart listing the default selections is included on the last three pages of this menu.

Disclaimer

Welch Allyn[®] reserves the right to make changes in specifications and other information contained in this document without prior notice, and the reader should in all cases consult Welch Allyn to determine whether any such changes have been made. The information in this publication does not represent a commitment on the part of Welch Allyn.

Welch Allyn shall not be liable for technical or editorial errors or omissions contained herein; nor for incidental or consequential damages resulting from the furnishing, performance, or use of this material.

This document contains proprietary information which is protected by copyright. All rights are reserved. No part of this document may be photocopied, reproduced, or translated into another language without the prior written consent of Welch Allyn, Incorporated.

© 1998 Welch Allyn, Inc. All rights reserved.

Automatic Set Up (“Plug and Play”)

The Plug and Play operation provides a method to automatically set up certain programmable options (including terminal I.D., data formatter, preambles and postambles) specific to the desired terminal interface. Using the Plug and Play single bar codes to set up the 2000 makes programming faster and easier.

The programmable options may be changed using the programming menu in the usual manner, thereby retaining programming flexibility.

Programming the SCANTEAM 2000 decoder for Plug and Play operation involves scanning the appropriate bar code (on the following pages) that identifies the desired terminal interface to be installed. To install and set up the decoder for Plug and Play, follow the steps below:

- 1) Disconnect power to the terminal/host device by turning the host system power switch to the “OFF” position.
- 2) Connect the appropriate interface cable to the decoder.
- 3) Connect the interface cable to the terminal/host device. (This may involve disconnecting a keyboard plug to the terminal, reconnecting the keyboard plug to the mating connector on the interface cable, then connecting the mating connector on the interface cable to the terminal.)
- 4) Once the decoder has been fully connected, restore power to the terminal/host device by turning the host system power switch to the “ON” position.
- 5) Scan the appropriate Plug and Play single bar code (on the following pages) for the terminal/host device interface desired. The Plug and Play bar codes are grouped in the following order on the next four pages:
 - IBM PC Interfaces
 - IBM 4683 Ports 5B, 9B and 17
 - OCIA Interfaces
 - OCR, RS232 and Wand Emulation Interfaces.

Other Programming Options

Not all terminals are Plug and Play programmable using a single bar code. Following the SINGLE BAR CODE pages is a section called TERMINAL I.D. SETUP. This section provides a bar code (“Terminal I.D. Settings”) that may be used to set up **any** of the supported terminal interfaces for the desired interface, plus a carriage return (CR) postamble, by scanning the terminal I.D.

Using the TERMINAL I.D. SETUP makes programming faster and easier (fewer programming scans) for simple terminal interface installations. Refer to the TERMINAL ID SETUP programming page for instructions on programming terminal interfaces other than the four most popular groupings listed above.

All of the supported terminal interfaces may be programmed in the usual manner for more complex or unique application requirements using the Terminal Selection, Output Parameters, Code Selection, and Data Formatter programming menu pages. Refer to these programming pages for all the programming features available in the SCANTEAM 2000.

**SINGLE BAR CODE
PROGRAMMING MENU
"PLUG AND PLAY"**

Welch Allyn [®]
SCANTEAM 2000 Programming Menu

❖ IBM PC Interface Selection ❖

IBM PC, XT Interface

Scan the bar code below to enable the IBM PC, XT Interface.

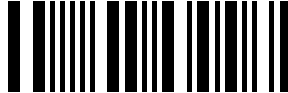

**IBM PC, XT
(2000/C & 2000/R)**

IBM PS/2, 25, 30, 55SX, 70 Interface

Scan the bar code below to enable the IBM PS/2 Interface.



**IBM PS/2
(2000/C & 2000/R)**

IBM PC, AT; PS/2 MOD30 (286) 50, 60, 70, 80 Interface

Scan the bar code below to enable the IBM PC, AT Interface.

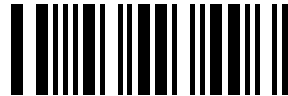

**IBM PC, AT and Compatibles
(2000/C & 2000/R)**

IBM PC Interface Cables Used	
IBM AT/XT and Compatibles	42204053-01
IBM PS/2 Series	42203978-01
IBM AT/XT/PS2 Series Combo	42204880-01

❖ **IBM 4683, 4693 Ports 5B, 9B and 17
 Interface Selection** ❖

IBM Port 5B Interface

Scan the bar code below to enable the IBM Port 5B Interface.



**IBM 4683, 4693 Port 5B
 (2000/R Only)**

IBM Port 9B Interface

Scan the bar code below to enable the IBM Port 9B Interface.



**IBM 4683, 4693 Port 9A/B HHBCR-1
 (2000/R Only)**

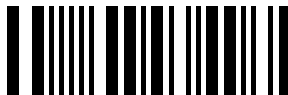

**IBM 4683, 4693 Port 9B HHBCR-2
 (2000/R Only)**

IBM Port 17 Interface

Scan the bar code below to enable the IBM Port 17 Interface.

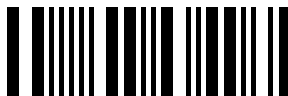

**IBM 4683, 4693 Port 17
 (2000/R Only)**

IBM 4683, 4693 Ports 5B, 9A/B and 17 Interface Cables Used	
IBM 4683, 4684, 4693, 4694 Port 5B	42204048-01
IBM 4683, 4684, 4693, 4694 Port 9A/B	42204248-01
IBM 4683, 4684, 4693, 4694 Port 17	42203979-01

IBM 4680 Postambles	
UPC-A 0D	EAN 13 16
UPC-E 0A	EAN 8 0C
Code 3 of 9 00 0A 0B	1 2 of 5 00 0D 0B
Code 128 00 0A 0B	

❖ **OCIA Interface Selection** ❖

Spectra–Physics OCIA Interface

Scan the bar code below to enable the Spectra–Physics OCIA Interface.



**Spectra–Physics OCIA
(2000/R Only)**

NCR OCIA Eight Bit (Short Format) Interface

Scan the bar code below to enable the NCR OCIA (short format) Interface.

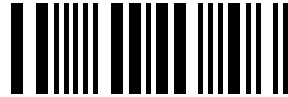

**NCR OCIA Short Format
(2000/R Only)**

NCR OCIA Nine Bit (Long Format) Interface

Scan the bar code below to enable the NCR OCIA (long format) Interface.



**NCR OCIA Long Format
(2000/R Only)**

Nixdorf OCIA Interface

Scan the bar code below to enable the Nixdorf OCIA Interface.

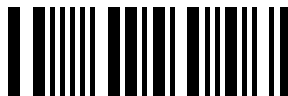

**Nixdorf OCIA
(2000/R Only)**

OCIA Interface Cables Used	
NCR 2152 OCIA	42203932–01
NCR 7052, 7150 OCIA	42204076–01
Nixdorf 8812 OCIA	42204051–01

❖ **OCR and RS-232 Interface Selection** ❖

Fujitsu OCR Interface

Scan the bar code below to enable the Fujitsu OCR Interface.



Fujitsu OCR
(2000/R Only)

IBM OCR (Port 21) Interface

Scan the bar code below to enable the IBM OCR (Port 21) Interface.



IBM OCR (Port 21)
(2000/R Only)

RS-232 Interface

Scan the bar code below to enable the RS-232 Interface.

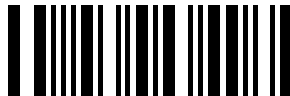

RS-232
(2000/C & 2000/R)

OCR and RS-232 Interface Cables Used	
IBM 4683 OCR (Port 21)	42204212-01 EP
Fujitsu 7770, 7990 OCR	42204085-01/4377-01 EP
Fujitsu 87S OCR	42204083-01 EP
Fujitsu OCR Atrium 9000 Series	42204082-01 EP

Note: EP = Requires external power. Refer to Welch Allyn Product Matrix for various RS-232 cables.

TERMINAL I.D. SETUP PROGRAMMING MENU “PLUG AND PLAY”

Welch Allyn [®]
SCANTEAM 2000 Programming Menu

Terminal I.D. Automatic Set Up (“Plug and Play”)

The Terminal I.D. Setup provides a “Plug and Play” method to automatically install **any** SCANTEAM 2000 supported terminal interface for the desired interface, plus a carriage return (CR) postamble. Using the TERMINAL I.D. SETUP makes programming faster and easier (fewer programming scans) for simple terminal interface installations.

Programming the 2000 for Terminal I.D. Plug and Play operation involves, first scanning the “Terminal I.D. Settings” bar code (on the facing page), then scanning the terminal I.D. digits that identify the desired terminal interface to be installed. To install and set up the decoder for Terminal I.D. Plug and Play, follow the steps below:

- 1) Disconnect power to the terminal/host device by turning the host system power switch to the “OFF” position.
- 2) Connect the appropriate interface cable to the decoder.
- 3) Connect the interface cable to the terminal/host device. (This may involve disconnecting a keyboard plug to the terminal, reconnecting the keyboard plug to the mating connector on the interface cable, then connecting the mating connector on the interface cable to the terminal.)
- 4) Once the decoder has been fully connected, restore power to the terminal/host device by turning the host system power switch to the “ON” position.
- 5) Scan the “Terminal I.D. Settings” bar code (on the opposite page).
- 6) Refer to the Terminal Selection programming pages for the two digit Terminal I.D. of the terminal interface you wish to install. (Terminal I.D.s may be found in the shaded “variables: scan” column down the right sides of the pages. *For example: an ADI terminal, model 1496, has a Terminal I.D. of 72.*)
- 7) Once the Terminal I.D. has been determined, scan the appropriate bar codes (on the opposite page) for those two digits.

The desired terminal interface, plus a carriage return (CR) postamble, should be installed for your application requirements.

Note: *All of the supported terminal interfaces may be programmed in the usual manner for more complex or unique application requirements using the Terminal Selection, Output Parameters, Code Selection, and Data Formatter programming menu pages. Refer to these programming pages for all the programming features available in the SCANTEAM 2000.*

Terminal I.D. Automatic Set Up ("Plug and Play")

- 1) Scan the "Terminal I.D. Settings" bar code below to install and set up the decoder for Terminal I.D. Plug and Play.

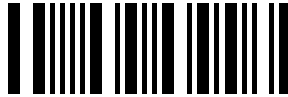

Terminal I.D. Settings

- 2) Scan the two terminal I.D. digits that identify the desired terminal interface to be installed (see TERMINAL SELECTION programming pages for 2-digit terminal IDs).

Digits



Letters



To Reset Factory Settings

To reset the SCANTEAM 2000 decoder to the factory settings, scan the bar code below. The factory settings are indicated by “*” (asterisks) on programming menu pages (Terminal Selection, Output Parameters, Code Selection, Data Formatter, etc.) in the shaded “variables: scan” column down the right sides of the pages.

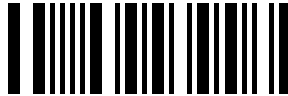

Factory Default Settings

USE THIS PAGE

■ As a general overview of the programming menu. The programming menu consists of two basic components as shown below.

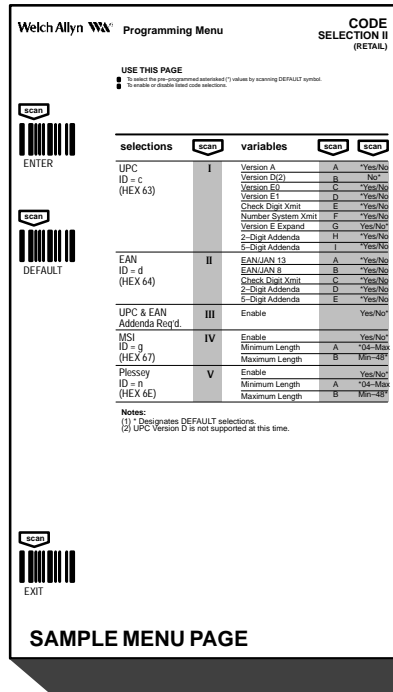

Welch Allyn  Programming Menu

CODE SELECTION II (RETAIL)

USE THIS PAGE
 ■ To select the pre-programmed selection(s) (*) by using the scan button.
 ■ To enable or disable listed code selections.

selections	scan	variables	scan	scan
UPC ID = c (HEX 43)	I	Version A A *Yes/No Version D(2) B No* Version 4(3) C *Yes/No Version E 1 D *Yes/No Check Digit Xmit E *Yes/No Number System Xmit F *Yes/No Version E Expand G *Yes/No 2-Digit Addenda H *Yes/No 5-Digit Addenda I *Yes/No		
EAN ID = d (HEX 64)	II	EAN/JAN 13 A *Yes/No EAN/JAN 8 B *Yes/No Check Digit Xmit C *Yes/No 2-Digit Addenda D *Yes/No 5-Digit Addenda E *Yes/No		
UPC & EAN Addenda Req'd.	III	Enable		Yes/No*
MSI ID = g (HEX 67)	IV	Enable *Yes/No Minimum Length A *04-Max Maximum Length B Min-48		
Plessey ID = h (HEX 6E)	V	Enable *Yes/No Minimum Length A *04-Max Maximum Length B Min-48		

Notes:
 (1) * Designates DEFAULT selections.
 (2) UPC Version D is not supported at this time.

SAMPLE MENU PAGE

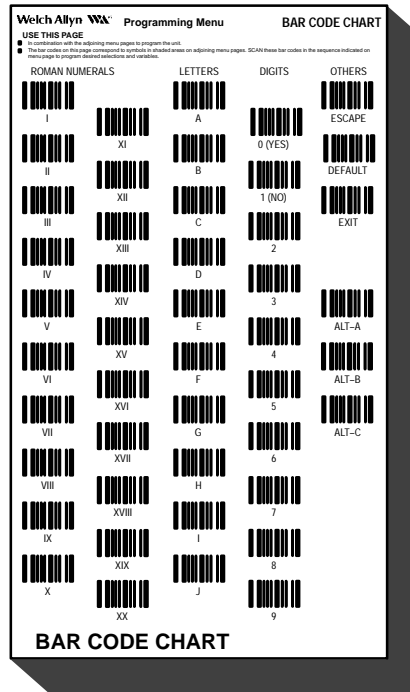

Welch Allyn  Programming Menu

BAR CODE CHART

USE THIS PAGE
 ■ To combine with the adjoining menu pages to program the unit.
 ■ The bar codes on this page correspond to symbols in shaded areas on adjoining menu pages. SCAN these bar codes in the sequence indicated on these pages to program desired selections and variables.

ROMAN NUMERALS	LETTERS	DIGITS	OTHERS
I	A	0 (YES)	ESCAPE
II	B	1 (NO)	DEFAULT
III	C	2	EXIT
IV	D	3	
V	E	4	ALT-A
VI	F	5	ALT-B
VII	G	6	ALT-C
VIII	H	7	
IX	I	8	
X	J	9	
XI			
XII			
XIII			
XIV			
XV			
XVI			
XVII			
XVIII			
XIX			
XX			

BAR CODE CHART

MENU PAGE

- Each menu page represents one section of the programming menu. Use individual menu pages in combination with the bar code chart on the back page foldout to program the decoder.
- **USE THIS PAGE** – is a summary of the programming options (parameters) of each menu page.
- **ENTER** – Each menu page has its own unique ENTER bar code; scan this bar code to activate desired menu page.
- **DEFAULT** – Most menu pages have a DEFAULT bar code which allows the user to independently default menu pages to asterisk (*) values without affecting, in any way, the rest of the programming menu. Default values can be easily selected from the desired menu pages by scanning the bar code sequence ENTER, DEFAULT, EXIT. Individual defaults for a specific selection can be made by scanning ENTER, ROMAN NUMERAL, DEFAULT, EXIT.
- **EXIT** – To move from one menu page to another, scan the EXIT bar code. This bar code must be scanned to end programming selection on each menu page before beginning to program on a different menu page.
- **SELECTIONS/VARIABLES** – Lists all of the options available on each menu page. Following each option are symbols in shaded areas. These symbols correspond to bar codes on the adjoining bar code chart.
- **NOTES** – are provided to call out any unusual situations and/or refer you to necessary information or examples elsewhere in the menu or manual.

MENU PAGE FACING (Not Shown)

- The page facing the menu is often used to supplement or clarify the material presented on the front of each menu page. The information and examples found here are specific to the individual menu page and contain, in some cases, charts and diagrams that must be used in order to determine the correct programming sequence.

BAR CODE DATA CHART

- The bar codes on this chart are assigned to a ROMAN NUMERAL, DIGIT, LETTER OR YES/NO symbol. These bar codes correspond to the symbols in shaded areas on the menu pages and are scanned in various combinations to enter programming sequences to the decoder. Bar codes on this page are meaningless unless an ENTER bar code from one of the menu pages is first scanned. When an ENTER bar code is scanned, the bar code chart becomes specific to that menu page and remains so until the EXIT bar code is scanned or another menu page is selected.

ESCAPE

- Use this bar code to cancel current programming sequence. All parameters remain as they were. Scan ESCAPE.

TERMINAL SELECTION

SCANTEAM 2000 Programming Menu

USE THIS PAGE

■ To program the 2000 for operation with one of the terminals listed below.



selections	variables	scan
ADDS	4000/110, 4000/160, 4000/260	03
ADI	1496	72
ALPHA MICRO SYSTEMS	AM-65	18
AMPEX	200 (4)	80
APPLE MACINTOSH (DESKTOP BUS)	MAC Classic, SE SE30, II (All) (4)	49
BULL	BDS-7 (HDS-7)	35
BULL QUESTAR	310 (2101 Keyboard) (4)	41
	310 (3105 Keyboard) (4)	42
BURROUGHS	B25 (4)	75
CITOH	326 (4)	85
COMPUTER LAB 122 key INTERNATIONAL	91, 196, 197, 476, 5476, 5477, 5488 (4)	92
COMTERM	6178	19
DATA GENERAL DASHER 217	Standard Keyboard (4)	68
	PC Keyboard (4)	A7
DATA POINT	8220, 8242	44
DEC	VT220, 320, 330, 340, 420	04
	VT510/520 PC Style Keyboard	05
	VT510/520/525 LK411 Keyboard (DEC Style)	A4
DECISION DATA	DDC3596, 3597	30
	DDC3761, 3791 (4)	40
102 key	DDC3496, 3497	84
122 key	DDC3496, 3497	71
102 key	DDC3776, 3777 (4)	83
122 key	DDC3776, 3777 (4)	73
122 key	DDC IS 386, IS 387	07



Notes:

- (1) Refer to the Welch Allyn Interface Products Work Center (IPWC) Terminal Interface/Cable Matrix (p/n 11208627) for cable part numbers.
- (2) No default setting exists for this page.
- (3) If a terminal is listed under two terminal ID selections, only one terminal ID can be used.
- (4) Not in standard 2000/C software. Must order via special 6 digit part number. Contact your Welch Allyn Sales Coordinator for 2000/C part number.

USE THIS PAGE

■ To program the 2000 for operation with one of the terminals listed below.



selections	variables	scan	
ESPRIT	200, 400	05	
ESPRIT III	(4)	21	
FALCO	5220	47	
FUJITSU	7770, 79990 OCR (5)	*	
FUJITSU	7770, 7990 OCR (5)	*	
FUJITSU	87S OCR (5)	*	
FUJITSU	OCR Atrium 9000 Series (5)	*	
HARRIS	H180, H191	09	
HEATH ZENITH		90	
HP	700/92, 700/94, 700/96, 700/98	20	
	700/44	96	
	700/32, 700/60	79	
	Vetra (Din and Mini Din connector)	03	
HUMAN DESIGNED SYSTEMS	HDS 2000	26	
	HDS 3200	27	
IBM	PC, XT	01	
	PS/2, 25, 30, 77DX2	02	
	AT, PS/2 30-286, 50, 55SX, 60, 70, 70-061, 70-121, 80, 3153	03	
	3278	11	
	5291-2	22	
	102 key	3151, 3161, 3162, 3163, 3179, 3182, 3191, 3192, 3194, 3196, 3197, 3471, 3472, 3476, 3477, 3486, 3488	06
	122 key	3179-1, 3191, 3192, 3471, 3472, 3194	07
		3196, 3197, 3476, 3477, 3482, 3486, 3487, 3488	08
		3180	24
		3178 (c1, c2)	10
IBM THINKPAD	750 Series	97	
IDEA COURIER	9291 (4)	88	
IDEASSOCIATES	276, 277, 486, 487, 587	08	
	102 key	276, 277, 486, 487, 587	84
	122 key	276, 277, 486, 487, 587	71
I/O	102 key (4)	1181/96/97, 2196, 2476/77, 2510/76/96	63
	122 key (4)	1181/96/97, 2196, 2476/77, 2510/76/96	76
	122 key	2676D, 2677C, 2677D	08



Notes:

- (1) Refer to the Welch Allyn Interface Products Work Center (IPWC) Terminal Interface/Cable Matrix (p/n 11208627) for cable part numbers.
- (2) No default setting exists for this page.
- (3) If a terminal is listed under two terminal ID selections, only one terminal ID can be used.
- (4) Not in standard 2000/C software. Must order via special 6 digit part number. Contact your Welch Allyn Sales Coordinator for 2000/C part number.

TERMINAL SELECTION continued



SCANTEAM 2000 Programming Menu

USE THIS PAGE

- To program the 2000 for operation with one of the terminals listed below.
- To program the 2000 to output data via the RS-232C aux port.

selections	variables	scan
ITT	9271	07
LEE DATA	IIS	07
LINK	125 (4)	67
	ANSI MC-3+, MC-5	15
	ASCII MC-3+, MC-5	14
	Enhanced PC MC-3+, MC-5	18
LINK	MCD 6420	A1
NCR	2920	03
NOKIA	KB100 (4)	65
OLIVETTI	M19, M24, M28, M200	01
OLIVETTI	M240, M250, M290, M380, P500	03
QUME	ANSI QVT 61, 62, 70, 191, 321, 322	82
	ASCII QVT 31, 51, 61, 62, 70, 191	74
	Enhanced PC QVT 61, 62, 70, 82, 191, Qx15	38
QUME	QVT520	A1
SERIAL WEDGE		50
SHERWOOD	ST6030 Enhanced PC (4), ST7000	78
SIEMENS 9758	(German Only)	34
SILICON GRAPHICS	Indy, Indigo II	05
STRATUS	V103	14
SUN SPARC 1+	(Both Type 5 Keyboards) (4)	86
TELEVIDEO	955, 965	36
	990, 995, 9060	02
TELEX	88 key 078, 078A, 79, 80, 191, 196, 1191, 1192, 1471, 1472, 1476	25
	102 key 078, 078A, 79, 80, 191, 196, 1151, 1191, 1192, 1471, 1472, 1476	45
	122 key 078, 078A, 79, 80, 191, 196, 1151, 1191, 1192, 1471, 1472, 1476, 1482	46
UNISYS	SVT 1120 (4)	81
	ANSI TO-300, 120	15
	ASCII TO-300, 120	14
	Enhanced PC TO-300, 120	18

Notes:

- (1) Refer to the Welch Allyn Interface Products Work Center (IPWC) Terminal Interface/Cable Matrix (p/n 11208627) for cable part numbers.
- (2) No default setting exists for this page.
- (3) If a terminal is listed under two terminal ID selections, only one terminal ID can be used.
- (4) Not in standard 2000/C software. Must order via special 6 digit part number. Contact your Welch Allyn Sales Coordinator for 2000/C part number.



USE THIS PAGE

- To program the 2000 for operation with one of the terminals listed below.
- To program the 2000 to output data via the RS-232C aux port.



selections	variables	
WYSE	WY-30/35	13
	WY-85/185	16
	WY-520	A1
	Serial Wedge, 25 Pin "D"	50
ANSI	WY 60, 120, 150, 160, 325, 370, 99GT	15
ASCII	WY 60, 120, 150, 160, 325, 370, 99GT	14
Enhanced PC	WY 60, 120, 150, 160, 325, 370	18
AUX PORT		00

Notes:

- (1) Refer to the Welch Allyn Interface Products Work Center (IPWC) Terminal Interface/Cable Matrix (p/n 11208627) for cable part numbers.
- (2) No default setting exists for this page.
- (3) If a terminal is listed under two terminal ID selections, only one terminal ID can be used.



OUTPUT PARAMETERS

SCANTEAM 2000 Information and Examples

Note: The Keyboard Style Table (2000/C) below applies to SCANTEAM 2000/C software prior to software revision level 5.2. The next page contains the Keyboard Style Table (2000/C) for software revision level 5.2.

KEYBOARD STYLE 2000/C

(If terminal is not listed, then no secondary type keyboard is supported.)

Terminal	Primary	Secondary	Tertiary	Quaternary	Quinquenary
IBM PC, PC/XT	XT	CAPS LOCK	SHIFT LOCK	"CTRL" + ASCII*	GrDOS SHIFT LOCK
IBM PC/AT	AT	CAPS LOCK	SHIFT LOCK	"CTRL" + ASCII*	GrDOS SHIFT LOCK
IBM PS2 (50-80)	NORM	CAPS LOCK	SHIFT LOCK	"CTRL" + ASCII*	GrDOS SHIFT LOCK
DEC VT	NORM	"CTRL" + ASCII*			
HDS 2000, 3200	T/W	"CTRL +"			
IBM 3180 (122 Key)	T/W	D/E			
IBM 3178	T/W	D/E		T/W + NUM KYPD	
COMTERM 6178	T/W	D/E			
TELEX (88 Key)	T/W	D/E			
SIEMENS 9758	NORM	CAPS LOCK			

* ASCII function codes (00-1F) are sent to the terminal via a "CTRL+" sequence (i.e. 'CR'=CTRL+M)

KEYBOARD STYLE 2000/R

Terminal	Primary	Secondary	Tertiary	Quaternary
IBM 3653	30 Key	48	N/A	
IBM 3683	35 Key	48 Key	52 Key	
NCR 2151	27 Key	32 Key	27 Key	
NCR 2152	27 Key	50 Key	NCR 2950 Terminal	
NCR 7052	34 Key	56 Key	122 Key Caps On	122 Key Caps Off

Terminal		Keyboard Style Selection for 2000/C								
ID	Name	A	B	C	D	F	G	H	I	J
		Primary	Secondary	Tertiary	Quaternary	DirCon	AutoCaps	NumPad	Turbo	Auto DC
04	DEC VT	std	CTRL ASCII							
1	IBM XT	std	CAPS LOCK	SHFT LOCK	CTRL ASCII	No	No	Yes	No	No
2	IBM PS/2	std	CAPS LOCK	SHFT LOCK	CTRL ASCII	Yes	Yes	Yes	12/9	Yes
3	IBM AT	std	CAPS LOCK	SHFT LOCK	CTRL ASCII	Yes	Yes	Yes	14/3	Yes
5	IBM AT3 DEC VT510	std	CAPS LOCK	SHFT LOCK	CTRL ASCII	Yes	Yes	Yes	14/11	Yes
6	IBMTerminals w/102 keys	std	CAPS LOCK	SHFT LOCK	No	No	Yes	Yes	No	No
7	IBMTerminals w/122 keys	std	CAPS LOCK	SHFT LOCK	No	No	Yes	Yes	No	No
8	IBMTerminals w/122 keys	std	CAPS LOCK	SHFT LOCK	No	No	Yes	Yes	No	No
9	Harris H180, H191	std			No	No			No	No
10	IBM 3178	std	D/E		No	No			No	No
11	IBM 3278	std	D/E		No	No			No	No
19	Comterm 6178	std	D/E		No	No			No	No
24	IBM 3180 122 Key	std	D/E		No	No			No	No
25	Telex 88 Key	std	D/E		No	No			No	No
26	HDS 2000	std	CTRL+							
27	HDS 3200	std	CTRL+							
34	Siemens 9758	std	CAPS LOCK							
35	BULL BDS-7 (HDS-7)	std	CAPS LOCK	SHFT LOCK	No	No			No	No
45	Telex 102 Key	std	CAPS LOCK	SHFT LOCK	No	No			No	No
46	Telex 122 Key	std	CAPS LOCK	SHFT LOCK	No	No			No	No
71	DDC 3496, 3497 122 Key	std	CAPS LOCK	SHFT LOCK	No	No			No	No
84	DDC 3496, 3497 102 Key	std	CAPS LOCK	SHFT LOCK	No	No			No	No
97	IBM Thinkpad	std	ob- solete	ob- solete	CTRL ASCII	ob- solete	ob- solete	Yes	No	N/A
A4	DEC VT510 LK411	std	CAPS LOCK	SHFT LOCK	CTRL ASCII	Yes	Yes	Yes	14/11	Yes

OUTPUT PARAMETERS continued

SCANTEAM 2000 Information and Examples

SYMBOLGY CHART

SYMBOLGY	Primary	ALT-A	ALT-B	ALT-C	CODE ID
UPC-A	63	83	A3	C3	c
EAN	64	84	A4	C4	d
MSI	67	87	A7	C7	g
PLESSEY	6E	8E	AE	CE	n
AMES	6B	8B	AB	CB	k
CODABAR	61	81	A1	C1	a
CODE-39	62	82	A2	C2	b
I 2 of 5	65	85	A5	C5	e
CODE 2 of 5	66	86	A6	C6	f
MATRIX 2 of 5	6D	8D	AD	CD	m
CODE-11	68	88	A8	C8	h
CODE-93	69	89	A9	C9	i
CODE 128	6A	8A	AC	CA	j
EAN-128	76	96	B6	D6	v
CODE 39 BASE 32	77	97	B7	D7	w
MSR TRACK 1	78	98	B8	D8	x
MSR TRACK 2	79	99	B9	D9	y
MSR TRACK 3	7A	9A	BA	DA	z
AUX PORT	72	92	B2	D2	r
UNIVERSAL	99	Preamble/Postamble ONLY			

USE THIS PAGE

- To default this page to asterisk (*) values.
- To set beeper volume and tone.
- To program keyboard style and layout.
- To program 4683 I/O Port; OCIA and OCR format selections.
- To program delay functions.



selections	scan	variables	scan
BEEPER VOLUME/TONE	I		0000–FFFF *(1919)
KEYBOARD STYLE	II	Primary	A*
		Secondary	B
		Tertiary	C
		Quaternary	D
		Dir Con	F
		Auto Caps	G
		NumPad	H
		Turbo	I
		Auto DC	J
KEYBOARD LAYOUT III (Keypad) (2000/R ONLY)	III	Layout 1 (Telephone)	A%
		Layout 2 (Calculator)	B
		Layout 3	C
4683 I/O PORT SELECTION (2000/R ONLY)	IV	Port 5B	A%
		Port 9B	B
		Port 17	C
		Port 5B/9B/17 Disable	D
OCIA FORMAT SELECTION (2000/R ONLY)	V	NCR 'S'	A%
		NCR 'F'	B
		Nixdorf	C
		Spectra Physics	D
OCR FORMAT SELECTION (2000/R ONLY)	VI	Fujitsu	A%
		IBM	B
INTERCHARACTER DELAY	VII	x5ms	*0000–9999
INTERFUNCTION DELAY	VIII	x5ms	*0000–9999
INTERMESSAGE DELAY	IX	x5ms	*0000–9999

Notes:

- (1) * Designates DEFAULT selections for the 2000/C and 2000/R.
- (2) # Designates DEFAULT 2000/C selections.
- (3) % Designates DEFAULT 2000/R selections.
- (4) The following are suggested Beeper Volume/Tone settings:

High	1919
Medium	4949
Low	0C0C
Off	0000

OUTPUT PARAMETERS continued

INTERCHARACTER DELAY INTERFUNCTION DELAY INTERMESSAGE DELAY

Intercharacter delay is the time delay (x5ms) between data characters output by the 2000.
 Interfunction delay is the time delay (x5ms) between "function key" characters output by the 2000.
 Intermessage delay is the time delay (x5ms) between records output by the 2000.

EXAMPLE: 2000 programmed as follows:
 Intercharacter delay = 10ms Interfunction delay = 50ms Postamble = Tab and Field Exit.
 When a bar code symbol containing the characters 123 is scanned, the 2000 will output to the terminal as follows:

```

1      10ms      2      10ms      3      10ms      Tab      50ms      Field Exit
  delay          delay          delay          delay          delay
    
```

PREAMBLE/POSTAMBLE

Preambles and postambles are characters added by the 2000 to barcode data. Preambles and postambles are assigned according to the barcode symbology using the symbology chart on page 6. Use the HEX-ASCII table below to find the ASCII value to be used for programming a particular preamble or postamble.

NOTE: The 2000 will translate characters 00-1F (keyboard function codes) into keyboard "function keys." The assigned translation is dependent upon the terminal being used. Refer to the 2000 Technical Manual to determine the assigned translation.

EXAMPLE: 1) To program a carriage return postamble for UPC-A symbology only, scan:

ENTER, XI, 6, 3, 0, D, F, F, EXIT

Where: ENTER (Output Parameter Page) enters programming mode.
 XI enters postamble programming.
 63 selects UPC symbology (see page 6, Symbology Chart).
 0D designates Carriage Return (see 2000 Technical Manual/Hex-ASCII chart below).
 FF terminates postamble programming.
 EXIT leaves programming mode.

EXAMPLE: 2) To program a carriage return postamble for ALL symbologies, scan:

ENTER, XI, 9, 9, 0, D, F, F, EXIT

Where: ENTER (Output Parameter Page) enters programming mode.
 XI enters postamble programming.
 99 selects ALL symbologies (see page 6, Symbology Chart).
 0D designates Carriage Return (see 2000 Technical Manual/Hex-ASCII chart below).
 FF terminates postamble programming.
 EXIT leaves programming mode.

Required Pre/Postambles for Particular Retail Terminals:

FUJITSU OCR POSTAMBLES	IBM 4680 PORT 5B POSTAMBLE	NIXDORF/SPECTRA OCIA
UPC-A 17 EAN 8 17	UPC-A 0D EAN 8 0C Code 3 of 9 00 0A 0B	PREAMBLES
UPC-E 17 EAN 13 17	UPC-D EAN 13 16 I 2 of 5 00 0D 0B	UPC-A 01
I 2 OF 5 03	UPC-E 0A Code 128 00 18 0B	UPC-E 05
(Application Dependent)		EAN-13 06
	NCR 'F' OCIA PREAMBLES	EAN-8 06, 06
NCR 'S' OCIA PREAMBLES	UPC-A 41 Code 3/9 42 31	NIXDORF OCIA PREAMBLES
UPC-A 0A EAN 8 OF OF	UPC-E 45 I 2 of 5 42 32	UPC/EAN w/ Addenda 44 4B
UPC-E OE EAN 13 OF	EAN-8 46 46 Code 128 42 33	Code 3/9 44 49
	EAN-13 46	I 2 of 5 44 48
IBM OCR POSTAMBLES	NCR 2123 MSR TRACK 2	Code 2 of 5 44 47
UPC-A 0D EAN 8 0C Code 128 1D	Preamble = 62 00	Code 93 44 4A
UPC-E 0A EAN 13 16	Postamble = 3D	Code 128 44 4A

NOTE: The IBM 4680 5B Port label format tables currently support only those symbologies listed above. Symbologies not supported such as Code 128 and Mag Stripe can be supported by assigning unused postambles. Example: Code 128, 00 0A 0B for Code 3 of 9 or Mag Stripe, 00 0D 0B for I 2 of 5.

COUNTRY CODE

The 2000 aligns the keyboard layout based on the Country Code selected here.

HEX - ASCII CHART

NUL 00	DLE 10	SP 20	0 30	@ 40	P 50	' 60	p 70
SOH 01	DC1 11	! 21	1 31	A 41	Q 51	a 61	q 71
STX 02	DC2 12	" 22	2 32	B 42	R 52	b 62	r 72
ETX 03	DC3 13	# 23	3 33	C 43	S 53	c 63	s 73
EOT 04	DC4 14	\$ 24	4 34	D 44	T 54	d 64	t 74
ENQ 05	NAK 15	% 25	5 35	E 45	U 55	e 65	u 75
ACK 06	SYN 16	& 26	6 36	F 46	V 56	f 66	v 76
BEL 07	ETB 17	' 27	7 37	G 47	W 57	g 67	w 77
BS 08	CAN 18	(28	8 38	H 48	X 58	h 68	x 78
HT 09	EM 19) 29	9 39	I 49	Y 59	i 69	y 79
LF 0A	SUB 1A	* 2A	: 3A	J 4A	Z 5A	j 6A	z 7A
VT 0B	ESC 1B	+ 2B	; 3B	K 4B	[5B	k 6B	{ 7B
FF 0C	FS 1C	, 2C	< 3C	L 4C	\ 5C	l 6C	7C
CR 0D	GS 1D	- 2D	= 3D	M 4D] 5D	m 6D	} 7D
SO 0E	RS 1E	. 2E	> 3E	N 4E	^ 5E	n 6E	~ 7E
SI 0F	US 1F	/ 2F	? 3F	O 4F	_ 5F	o 6F	DEL 7F

FUNCTION CODE

YES - SCANTEAM 2000 translates characters 00-1F (keyboard function codes) that may be contained within records into "function keys." These function keys will be sent to the terminal along with the other characters in the record.

NO - The 2000 does not translate characters 00-1F into keyboard "function keys." Instead, characters 00-1F are stripped from the record.

NOTE: Keyboard function codes that are programmed in the postamble and preamble remain active at all times.

USE THIS PAGE

- To default this page to asterisked (*) values.
- To set preamble and postamble.
- To program output modes and wand/laser port modes.
- To program a country code.

selections	scan	variables	scan	scan
PREAMBLE	X	Symbology or 99 Universal (ALL)	(See Chart Pg. 6)	
		Preamble(s) (4,5,6,7)	*00-7F	FF
POSTAMBLE	XI	Symbology or 99 Universal (ALL)	(See Chart)	
		Postamble(s) (4,5,6,7)	*00-7F	FF
OUTPUT MODES	XII	Buffer Scans	A	*Yes/No
		Input Inhibit	B	Yes/No*
		Code ID Transmit	C	Yes/No*
		Function Code Transmit (2000/C ONLY)	D	#Yes/No
		OCIA and Wedge (2000/R ONLY)	E	Yes/No%
		IBM 4680 Dual Track MSR Track 1 & 2 (8) (2000/R ONLY)	F	Yes/No%
		IBM 4680 Dual Track MSR Track 2 & 3 (8) (2000/R ONLY)	G	Yes/No%
		AIM ID	H	Yes/No#
		Scanner Port ID (2000/C ONLY)	I	Yes/No#
		WAND/LASER PORT MODES	XIII	Hand Held Laser Timeout
Laser Redundancy	B			#Yes/No%
Dual Wand	C			#Yes/No%
Constant Scan CCD (2000/R ONLY)	D			Yes/No%
Hands-Free Stand Timeout x33ms (2000/R ONLY)	E			0000-FFFF (C5C1%)
COUNTRY CODE	XIV	United States		00*
		Belgium		01
		Denmark (9)		02
		Finland		
		Norway (9)		
		Sweden		
		France		03
		Germany/Austria		04
		Italy		05
		Switzerland		06
		United Kingdom		07
		Denmark (WYSE)		08
		Norway (WYSE)		09
Spain		10		

- Notes:**
- (1) * Designates DEFAULT selections for the 2000/C and 2000/R.
 - (2) # Designates DEFAULT 2000/C selections.
 - (3) % Designates DEFAULT 2000/R selections.
 - (4) Scan FF to terminate a pre/postamble.
 - (5) To clear a pre/postamble of a particular symbology, scan ENTER, the Symbology, and FF.
 - (6) Default clears all pre/postambles of all symbologies.
 - (7) To program Code ID scan the ASCII representation of Code ID on the Symbology and HEX ASCII Charts on pages 4 and 6 of this menu.
 - (8) Start/Stop and LRC characters will be disabled.
 - (9) Use special Wyse selection when using Wyse terminals.



OUTPUT SERIAL WEDGE 2000/C ONLY

SCANTEAM 2000 Information and Examples

The SCANTEAM 2000 includes programmable output parameters for serial wedge. Program the serial wedge to meet your requirements.

Output

To Host/Terminal: Sends data to both Host and Terminal.
To Host: Sends data to Host only. Terminal remains in loop through mode.
To Terminal: Sends data to terminal only. Host remains in loop through mode.

Baud Rate

The baud rate is programmable from 300 bits per second to 19,200 bits per second. Programming the 2000 to the desired baud rate causes the data to be sent at the specified rate.

Parity

Parity provides a means of checking data bit patterns for validity. The four choices are Space, Mark, Odd, and Even. The parity should be programmed to match the parity of the terminal being used. If the parity is not set correctly, the resulting data may be incorrect.

Data Bits

The two choices for data bits are seven and eight. The data bits selection must match the requirements of the terminal being used.

USE THIS PAGE

■ To default this page to asterisked (*) values.

scan

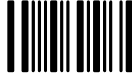

ENTER

scan



DEFAULT

selections	scan	variables	scan
OUTPUT (2000/C ONLY)	I	To Host/Terminal	A#
		To Terminal	B
		To Host	C
BAUD RATE (2000/C ONLY)	II	300	A
		600	B
		1200	C
		2400	D
		4800	E
		9600	F#
		19200	G
PARITY (2000/C ONLY)	III	Space	A
		Mark/None (for 8 Data Bits)	B
		Odd	C
		Even	D#
DATA BITS (2000/C ONLY)	IV	Seven	A#
		Eight	B

scan

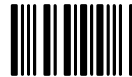

EXIT

Notes:

(1) # Designates DEFAULT 2000/C selections.

CODES INDUSTRIAL

SCANTEAM 2000 Information and Examples

INDUSTRIAL CODE OUTPUT FORMATS

CODABAR	aSX ... XCS
Code 3 of 9	bSXX .. XXCS
INTERLEAVED 2 of 5	eXX ... XXC
Code 2 of 5	fXX XX
Code 11	hXX ... XXCC
Code 93	iXX XX
Code 128	jXX XX
Matrix 2 of 5	mXX ... XX

Where: a = CODABAR Code ID
b = Code 3 of 9 ID
e = INTERLEAVED 2 of 5 ID
f = 2 of 5 ID
h = Code 11 ID
i = Code 93 ID
j = Code 128 ID
m = Matrix 2 of 5 ID
o = Code 16K
S = Start/Stop Character
X = Data Character
C = Checksum Character

NOTE: Appropriate code identification must be programmed in a preamble. Proper parameters must be enabled for Start/stop and Checksum characters to be transmitted. **For maximum data security, disable the Codes not used.**

CODE SELECTION I (INDUSTRIAL)

USE THIS PAGE

- To select the pre-programmed asterisk (*) values by scanning DEFAULT symbol.
- To enable or disable listed code selections.



selections		scan	variables	scan	scan
CODABAR ID = a (HEX 61)	I	Enable		#Yes/No%	
		Minimum Length	A	*01–Max	
		Maximum Length	B	Min–60*	
		S/S Xmit	C	Yes/No*	
		Check Char. Req'd	D	Yes/No*	
		Xmit Check Char.	E	Yes/No*	
		Concatenation	F	#Yes/No%	
		Concatenation Req'd	G	Yes/No*	
CODE 39 ID = b (HEX 62)	II	Enable		*Yes/No	
		Minimum Length	A	*00–Max	
		Maximum Length	B	Min–48*	
		S/S Xmit	C	Yes/No*	
		Check Char. Req'd	D	Yes/No*	
		Xmit Check Char.	E	Yes/No*	
		Full ASCII	F	*Yes/No	
		Append Option	G	Yes/No*	
INTERLEAVED 2 OF 5 ID = e (HEX 65)	III	Enable		#Yes/No%	
		Minimum Length (4)	A	02–Max	
		Maximum Length	B	Min–80*	
		6, 14 & 16 Only	C	Yes/No*	
		Check Digit Req'd	D	Yes/No*	
		Xmit Check Digit	E	Yes/No*	
CODE 2 OF 5 ID = f (HEX 66)	IV	Enable		#Yes/No%	
		Minimum Length (4)	A	01–Max	
		Maximum Length	B	Min–48*	
MATRIX 2 OF 5 ID = m (HEX 6D)	V	Enable		#Yes/No%	
		Minimum Length (4)	A	01–Max	
		Maximum Length	B	Min–80*	
CODE 11 ID = h (HEX 68)	VI	Enable		#Yes/No%	
		Minimum Length (4)	A	01–Max	
		Maximum Length	B	Min–80*	
		2 Check Digits (N=1)	C	*Yes/No	
CODE 93 ID = i (HEX 69)	VII	Enable		#Yes/No%	
		Minimum Length	A	*00–Max	
		Maximum Length	B	Min–64*	
CODE 16K (5) (2000/C ONLY) ID = o (HEX 6F)	IX	Enable		Yes/No#	
		Minimum Length (4)	A	*00–Max	
		Maximum Length	B	Min–154	
DISABLE ALL CODES (Including Retail)	XIX			Yes/No*	
DECODING ALGORITHM	XX	Codabar	A	Adap/Trad *Y/N	
		Code 39	B	Adap/Trad *Y/N	
		Interleaved 2 of 5	C	Adap/Trad %Y/N#	

Notes:

- (1) * Designates DEFAULT selections for the 2000/C and 2000/R.
- (2) # Designates DEFAULT 2000/C selections.
- (3) % Designates DEFAULT 2000/R selections.
- (4) The DEFAULT Minimum Length for these codes is 4 characters.
- (5) Available with special software, ordered under six digit part number.



CODES INDUSTRIAL

SCANTEAM 2000 Information and Examples

FULL ASCII CODE 3 OF 9 CHARACTERS

If full ASCII Code 3 of 9 decoding is enabled, certain character pairs within the bar code symbol will be interpreted as a single character. For example: \$V will be decoded as the ASCII character SYN, and /C will be decoded as the ASCII character #.

FULL ASCII CODE 3 OF 9 CHART

NUL	%U	DLE	\$P	SP	SPACE	0	0	@	%V	P	P	'	%W	p	+P
SOH	\$A	DC1	\$Q	!	/A	1	1	A	A	Q	Q	a	+A	q	+Q
STX	\$B	DC2	\$R	"	/B	2	2	B	B	R	R	b	+B	r	+R
ETX	\$C	DC3	\$S	#	/C	3	3	C	C	S	S	c	+C	s	+S
EOT	\$D	DC4	\$T	\$	/D	4	4	D	D	T	T	d	+D	t	+T
ENQ	\$E	NAK	\$U	%	/E	5	5	E	E	U	U	e	+E	u	+U
ACK	\$F	SYN	\$V	&	/F	6	6	F	F	V	V	f	+F	v	+V
BEL	\$G	ETB	\$W	'	/G	7	7	G	G	W	W	g	+G	w	+W
BS	\$H	CAN	\$X	(/H	8	8	H	H	X	X	h	+H	x	+X
HT	\$I	EM	\$Y)	/I	9	9	I	I	Y	Y	i	+I	y	+Y
LF	\$J	SUB	\$Z	*	/J	:	/Z	J	J	Z	Z	j	+J	z	+Z
VT	\$K	ESC	%A	+	/K	;	%F	K	K	[%K	k	+K	{	%P
FF	\$L	FS	%B	,	/L	<	%G	L	L	\	%L	l	+L		%Q
CR	\$M	GS	%C	-	-	=	%H	M	M]	%M	m	+M	}	%R
SO	\$N	RS	%D	.	.	>	%I	N	N	^	%N	n	+N	~	%S
SI	\$O	US	%E	/	/O	?	%J	O	O	_	%O	o	+O	DEL	%T

Character pairs /M and /N decode as a minus sign and period respectively.
Character pairs /P through /Y decode as 0 through 9.

MIN/MAX LENGTH

These variables are used to require that bar code symbols contain a character count within a certain range. Bar codes with counts outside this range will not be decoded.

EXAMPLE: Decode only those bar codes with a count of 9–20 characters.

Min. length = 09

Max. length = 20

EXAMPLE: Decode only those bar codes with a count of 15 characters.

Min. length = 15



Max. length = 15

CODE SELECTION I (INDUSTRIAL) continued

USE THIS PAGE

- To select the pre-programmed asterisk (*) values by scanning DEFAULT symbol.
- To enable or disable listed code selections.



selections		variables		
CODE 128	ID = j (HEX 6A)	VIII	Enable	*Yes/No
			Minimum Length	A *00-Max
			Maximum Length	B Min-80*
EAN-128	ID = v (HEX 76)	VIII	Enable	C Yes/No*
			EAN-128 Minimum Length	D *00-Max
			EAN-128 Maximum Length	E Min-80*
ISBT-128		X	Enable	Yes/No*

Notes:

- (1) * Designates DEFAULT selections for the 2000/C and 2000/R.
- (2) # Designates DEFAULT 2000/C selections.
- (3) % Designates DEFAULT 2000/R selections.



CODES RETAIL

RETAIL CODE OUTPUT FORMATS

Non-Zero Suppressed UPC-A and UPC-E Output Format

UPC-A	cXXXXXXXXXXC
UPC-A with 2 digit addenda	cXXXXXXXXXXC-AA
UPC-A with 5 digit addenda	cXXXXXXXXXXC-AAAAA
UPC-E	cXXXXXXXXXXC
UPC-E with 2 digit addenda	cXXXXXXXXXXC-AA
UPC-E with 5 digit addenda	cXXXXXXXXXXC-AAAAA

Zero Suppressed UPC-A and UPC-E Output Format

UPC-A	cXXXXXXXXXXC
UPC-A with 2 digit addenda	cXXXXXXXXXXC-AA
UPC-A with 5 digit addenda	cXXXXXXXXXXC-AAAAA
UPC-E	cXXXXXXXXC
UPC-E with 2 digit addenda	cXXXXXXXXC-AA
UPC-E with 5 digit addenda	cXXXXXXXXC-AAAAA

EAN/JAN Output Format

EAN/JAN-13	dffXXXXXXXXXXC
EAN/JAN-13 with 2 digit addenda	dffXXXXXXXXXXC-AA
EAN/JAN-13 with 5 digit addenda	dffXXXXXXXXXXC-AAAAA
EAN/JAN-8	dffXXXXXC
EAN/JAN-8 with 2 digit addenda	dffXXXXXC-AA
EAN/JAN-8 with 5 digit addenda	dffXXXXXC-AAAAA

Where: c = UPC Code ID
d = EAN/JAN Code ID
k = AMES ID
N = Number System Character
f = Identification Flag
X = Data Character
C = Checksum Character
- = Space
A = Addenda Character

NOTE: Appropriate code identification must be programmed in a preamble. Proper parameters must be enabled for number system, checksum, and addenda characters to be transmitted. **For maximum data security, disable the Codes not used.**

UPC/EAN LENGTH CHART

selections	Basic Length	W/out Ck. Digit	W/out Sys. Digit	W/2 Digit Addendum	W/5 Digit Addendum	TOTAL
UPCA	12	-01	-01	+02	+05	
UPCE [w/0's suppressed]	8	-01	-01	+02	+05	
UPCE [expanded]	12	-01	-01	+02	+05	
UPCD1	14	-01	-01	+02	+05	
UPCD2	20	-02	-01	+02	+05	
UPCD3	24	-02	-01	+02	+05	
UPCD4	28	-03	-01	+02	+05	
UPCD5	32	-03	-01	+02	+05	
EAN8	8	-01	N/A	+02	+05	
EAN13	13	-01	N/A	+02	+05	

USE THIS PAGE

- To select the pre-programmed asterisk (*) values by scanning DEFAULT symbol.
- To enable or disable listed code selections.



selections		scan	variables	scan	scan
UPC	ID = c (HEX 63)	I	Version A	A	*Yes/No
			Version D(4)	B	No*
			Version E0	C	*Yes/No
			Version E1	D	*Yes/No
			Check Digit Xmit	E	%Yes/No#
			Number System Xmit	F	%Yes/No#
			Version E Expand	G	Yes/No*
			2-Digit Addenda	H	*Yes/No
			5-Digit Addenda	I	*Yes/No
EAN	ID = d (HEX 64)	II	EAN/JAN 13	A	*Yes/No
			EAN/JAN 8	B	*Yes/No
			Check Digit Xmit	C	%Yes/No#
			2-Digit Addenda	D	*Yes/No
			5-Digit Addenda	E	*Yes/No
UPC & EAN ADDENDA REQ'D.		III	Enable		Yes/No*
MSI	ID = g (HEX 67)	IV	Enable		#Yes/No%
			Minimum Length	A	*04-Max
			Maximum Length	B	Min-48*
PLESSEY	ID = n (HEX 6E)	V	Enable		#Yes/No%
			Minimum Length	A	*04-Max
			Maximum Length	B	Min-48*
UPC/EAN ADDENDA FORMAT		VII	With space		*Yes/No



Notes:

- (1) * Designates DEFAULT selections for the 2000/C and 2000/R.
- (2) # Designates DEFAULT 2000/C selections.
- (3) % Designates DEFAULT 2000/R selections.
- (4) UPC Version D is not supported at this time.

AUXILIARY PORT 1

SCANTEAM 2000 Information and Examples

INTRODUCTION

The 2000 Auxiliary port menu is used to (1) Program the 2000's Auxiliary Port communication parameters and protocols and (2) Enable/disable output of keyboard function codes contained in incoming data.

Refer to the **SCANTEAM 2000 Technical Manual** for detailed information about all items on the 2000 Auxiliary Port programming menu.

HEX — ASCII CHART

NUL 00	DLE 10	SP 20	0 30	@ 40	P 50	' 60	p 70
SOH 01	DC1 11	! 21	1 31	A 41	Q 51	a 61	q 71
STX 02	DC2 12	" 22	2 32	B 42	R 52	b 62	r 72
ETX 03	DC3 13	# 23	3 33	C 43	S 53	c 63	s 73
EOT 04	DC4 14	\$ 24	4 34	D 44	T 54	d 64	t 74
ENQ 05	NAK 15	% 25	5 35	E 45	U 55	e 65	u 75
ACK 06	SYN 16	& 26	6 36	F 46	V 56	f 66	v 76
BEL 07	ETB 17	' 27	7 37	G 47	W 57	g 67	w 77
BS 08	CAN 18	(28	8 38	H 48	X 58	h 68	x 78
HT 09	EM 19) 29	9 39	I 49	Y 59	i 69	y 79
LF 0A	SUB 1A	* 2A	: 3A	J 4A	Z 5A	j 6A	z 7A
VT 0B	ESC 1B	+ 2B	; 3B	K 4B	[5B	k 6B	{ 7B
FF 0C	FS 1C	, 2C	< 3C	L 4C	\ 5C	l 6C	7C
CR 0D	GS 1D	- 2D	= 3D	M 4D] 5D	m 6D	} 7D
SO 0E	RS 1E	. 2E	> 3E	N 4E	^ 5E	n 6E	~ 7E
SI 0F	US 1F	/ 2F	? 3F	O 4F	_ 5F	o 6F	DEL 7F

END OF RECORD

Marks the end of an incoming data record from the Auxiliary Port. Use the HEX ASCII chart above to find the alpha-numeric codes used for programming a particular End of Record. The 2000 does not send End of Record characters to the terminal.

PROTOCOL

A set of rules governing the exchange of data between communications devices. See **SCANTEAM 2000 Technical Manual** for a description of supported protocols.

FUNCTION CODES

The 2000 translates the characters Hex 01-0F (keyboard function codes) that may be contained within Auxiliary Port records into keyboard "function keys." Note, however, that the Function Codes are determined by the selections made on the 2000 Programming Menu.

USE THIS PAGE

- To select the pre-programmed asterisk (*) values by scanning DEFAULT symbol.
- To program auxiliary port communication parameters and protocol.
- To enable/disable output of keyboard function codes contained in incoming data.



selections	scan	variables	scan	scan
BAUD RATE	I	300	A	
		600	B	
		1200	C	
		2400	D	
		4800	E	
		9600	F*	
		19,200	G	
		38,400	H	
PARITY	II	None	A	
		Mark	B	
		Space	C	
		Odd	D%	
		Even	E#	
DATA LENGTH (2000/C ONLY)	III	Seven Bits	A#	
		Eight Bits	B	
PROTOCOL (2000/C ONLY)	IV	Record	A#	
		Burst	B	
		ACK/NAK Record Mode	C	
		ACK/NAK Block Mode	D	
PROTOCOL (2000/R ONLY)	IV	End of Rec. Char	A%	
		End of Rec Timeout (60 ms)	B	
START OF RECORD CHAR. (2000/C ONLY)	V			#00-7F
END OF RECORD	VI			00-7F (*0D=CR)
START OF BLOCK CHAR. (2000/C ONLY)	VII			#00-7F
END OF BLOCK CHAR. (2000/C ONLY)	VIII			00-7F (#04=EOT)
FUNCTION CODES (2000/C ONLY)	IX			#Yes/No
SOLICIT MODE (2000/C ONLY)	X	Disable	A#	
		One for One	B	
		On Match	C	
SOLICIT MESSAGE (2000/C ONLY)	XI			00-7F (16 chars max.)
SOLICIT MATCH STRING (2000/C ONLY)	XII			00-7F (16 chars max.)
CTS CHECK (TRANSMIT)	XX			#Yes/No%
4683 ASYNC ADDRESS	XIX	Async Port Disable	A%	
		\$64	B	
		\$65	C	
		\$68	D	
		\$69	E	



Notes:

- (1) * Designates DEFAULT selections for the 2000/C and 2000/R.
- (2) # Designates DEFAULT 2000/C selections.
- (3) % Designates DEFAULT 2000/R selections.

DATA FORMATTING EDITOR COMMANDS

SCANTEAM 2000 Information and Examples

COMMAND	ACTION
F1	Send all characters followed by "XX" key or function code, starting from current cursor position. ** Syntax = F1XX XX = HEX ASCII character or function code 00–FE HEX
F2	Send "NN" characters followed by "XX" key or function code, starting from current cursor position. ** Syntax = F2NNXX NN = No. of Characters 00–99 DEC. XX = HEX ASCII character or function code 00–EF HEX
F3	Send up to but not including "SS" character, (** Search and Send**) Starting from current cursor position, leaving cursor pointing to "SS" Char. followed by "XX" key or function code. ** Syntax = F3SSXX SS = HEX ASCII Character 00–7F HEX. XX = HEX ASCII character 00–7F HEX.
F4	Send "XX" character "NN" times, (**INSERT**) Leaving cursor in current cursor position. ** Syntax = F4XXNN XX = HEX ASCII character 00–7F HEX NN = No. of characters 00–99 DEC.
F5	Move cursor ahead "NN" characters from current cursor position. ** Syntax = F5NN NN = No. of characters 00–99 DEC.
F6	Move cursor back "NN" characters from current cursor position. ** Syntax = F6NN NN = No. of characters 00–99 DEC.
F7	Move cursor to the beginning of the data string. ** Syntax = F7
F8	Search ahead for "XX" character from current cursor position, leaving cursor pointing to "XX" char. ** Syntax = F8XX XX = HEX ASCII character 00–7F.
F9	Search back for "XX" character from current cursor position, leaving cursor pointing to "XX" char. ** Syntax = F9XX XX = HEX ASCII character 00–7F.
FA	Leading zero suppress on Suppress leading zeroes from current cursor position until 1st non-zero char. ** Syntax = FA
FB	Suppress "XX" character(s) up to 3 starting from current cursor position until suppress disable command "FC" or end of format. ** Syntax = FBXXFB, FBXXXXFB, FBXXXXXXXXFB XX = ASCII Char 00–7F.
FC	Disable suppress filter and clear all suppressed characters. ** Syntax = FC
FD	DCA mode ON/OFF (Toggle) Convert characters to DCA starting from current cursor position until next "FD" command or end of format. (2000/R ONLY) ** Syntax = FD
FE	Compare character in current cursor position to the character "XX." If characters are equal, increment cursor. If characters are not equal, no format match. ** Syntax = FEXX XX = HEX ASCII Character 00 –7F
EB	Solicit auxiliary port mode ON/OFF (Toggle) Send characters out auxiliary port using F1, F2, F3, F4 commands. **Syntax=EB (2000/C ONLY)
EA	Move cursor to the last valid character of the data string. **Syntax = EA
EC	Check for numeric character at current cursor position. If true, then continue format. If false, then no format. (2000/C ONLY)
ED	Check for non-numeric character at current cursor position. If true, then continue format. If false, then no format. (2000/C ONLY)
EE	Leading space suppress on. Suppress leading spaces from current cursor position until first non-space character. ** Syntax = EE
EF	Delay function. **Syntax = EFXXXX XXXX = 0000–FFFF x 5ms delay. (2000/R ONLY)
E9	Send all but the last "NN" characters from the current cursor position. **Syntax = E9NN NN = No. of characters 00 - 99 Dec.)



selections scan variables scan

FORMAT REQUIRED? **I** Yes/No*

scan scan scan scan scan scan

Terminal Code Length Editor End
Type ID Sequences

II (*) () (*) () (FF)
* You may use Universal Number of 99.

selections	scan	variables	scan	scan
MSR DATA	III	Start/Stop Char. Transmit	A	%Yes/No#
		LRC Char. Transmit	B	%Yes/No#
MSR TRACK SELECTION	IV	Track 1 Enable	A	*Yes/No
		Track 2 Enable	B	*Yes/No
		Track 3 Enable	C	*Yes/No
MSR TRACK 2 PRE-EDITED DATA FORMATS	V	Clear Pre-edited Data Format	A	
		Acct # + Key-Code 1	B	
		Acct # + Key-Code 1 + YYMM + Key-Code 2	C	
		Acct # + Key-Code 1 + MMY Y + Key-Code 2	D	
		Acct # + Key-Code 1 + YYMM+ Key-Code 2 + All Remaining Data + Key-Code 3	E	
		Acct # + Key-Code 1 + MMY Y+ Key-Code 2 + All Remaining Data + Key-Code 3	F	
MSR TRACK 1 PRE-EDITED DATA FORMATS	VI	Clear Pre-edited Data Format	A	
		Acct # + Key-Code 1 + YYMM + Key-Code 2 + Name + Key-Code 3	B	
		Acct # + Key-Code 1 + MMY Y + Key-Code 2 + Name + Key-Code 3	C	
		Acct # + Key-Code 1 + YYMM+ Key-Code 2 + Name + Key-Code 3 + All Remaining Data + Key-Code 4	D	
		Acct # + Key-Code 1 + MMY Y+ Key-Code 2 + Name + Key-Code 3 + All Remaining Data + Key-Code 4	E	
KEY-CODE 1-4 ASSIGNMENT (Assignable Delimiter or Function Codes all default to "0D.")	VII	Key-Code 1 (E0H) (4)	A	00-FE *0D
		Key-Code 2 (E1H) (4)	B	00-FE *0D
		Key-Code 3 (E2H) (4)	C	00-FE *0D
		Key-Code 4 (E3H) (4)	D	00-FE *0D
DELETE ALL FORMATS	XX	Are You Sure?		Yes/No

Notes:
 (1) * Designates DEFAULT selections for the 2000/C and 2000/R.
 (2) # Designates DEFAULT 2000/C selections.
 (3) % Designates DEFAULT 2000/R selections.
 (4) 2000/C cannot program above 7F.

DATA FORMATTING EDITOR

SCANTEAM 2000 Examples

Bar Code Format Example (Retail)

IBM 3683, Code 128, 19 characters, 4 fields

Field 1 = 3 Char. + A9 Func. Code
 Field 2 = 3 Char. + B0 Func. Code
 Field 3 = 7 Char. + B1 Func. Code
 Field 4 = 6 Char. + B2 Func. Code, Leading Zero Suppress
 Raw Data String: 5429990001066003456
 Format Syntax: 07,6A,19 F2 03 A9, F2 03 B0, F2 07 B1, FA, F2 06 B2, FF
 07 = Terminal Type 3683
 6A = 'j' Code 128 Code ID.
 19 = Label Length

Command	Cursor Position	Output Data String
Start	5429990001066003456	
F2 03 A9	5429990001066003456	542+A9
F2 03 B0	5429990001066003456	542+A9+999+B0
F2 07 B1	5429990001066003456	542+A9+999+B0+0001066+B1
FA F2 06 B2	5429990001066003456	542+A9+999+B0+0001066+B1+3456+B2
FF = Stop		

Magnetic Stripe Reader Format Example (Retail)

IBM 3683, MSR Track 2

Field 1 = Acct # + B2 Func. Code
 Field 2 = Exp. Date MM/YY + B2 Func. Code
 Field 3 = All Remaining + B2 Func. Code
 No Field Separator, Start/Stop, LRC.
 Raw Data String: ;1234567890123456=9202891100106600345?R
 Format Syntax: 07,78,99 F5 01, F3 3D B2, F5 03, F2 02 00, F6 04, F2 02 B2, F5 02, F3 3F B2, FF
 07 = Terminal Type 3683
 79 = 'y' MSR Track 2
 00 = Label Length

Command	Cursor Position	Output Data String
Start	;1234567890123456=9202891100106600345?R	
F5 01	;1234567890123456=9202891100106600345?R	
F3 3D B2	;1234567890123456=9202891100106600345?R	1234567890123456+B2
F5 03	;1234567890123456=9202891100106600345?R	
F2 02 00	;1234567890123456=9202891100106600345?R	1234567890123456+B2+02
F6 04	;1234567890123456=9202891100106600345?R	
F2 02 B2	;1234567890123456=9202891100106600345?R	1234567890123456+B2+0292+B2
F5 02	;1234567890123456=9202891100106600345?R	
F3 3F B2	;1234567890123456=9202891100106600345?R	1234567890123456+B2+0292+B2+891100106600345+B2
FF = Stop		

Retail Wedge Terminal Type Table

Terminal	Terminal Type Number	Terminal	Terminal Type Number
Aux Port	00	IBM 3683	07
NCR 2152	01	IBM 4683	08
NCR 2151	02	OCIA	09
IBM 3653	03	NCR 7052	48
OCR	05	Universal	99
NCR 280	06		

Bar Code Example (Commercial)

Scenario: You need to read a 6–digit bar code printed in Interleaved 2 of 5. Only the first five digits of the code will be transmitted. You want the transmitted code terminated with a vertical tab and a horizontal tab.

Solution: On the Data Formatter Page of this menu:

Step 1: Scan ENTER.

Step 2: Scan I and Yes (enables data formatting)

Step 3: Scan XX and Yes (clears previous formats)

Step 4: Scan II (**Enter Data Formatting Parameters**)

Scan 03 for terminal type (PC)

Scan 65 for Code I 2 of 5 Symbology (Primary from Symbology chart on page 4 of this menu.

Scan 06 for length (fixed length code)

Format Parameters: (Sequence to be scanned for label format from the Bar Code Chart in the back of this menu.)

F2 05 0B F4 09 01 FF

Scan each character separately (i.e., scan F, scan 2, scan 0, etc.)

F2 05 0B: F2 is the send xx number of characters followed by a function code. Send the first five characters of the label followed by a vertical tab. (Hex 0B)

F4 09 01: Append one hex 09 (a horizontal tab) at the end of the label.

FF: Termination character for the end of the format.

Scan EXIT

Try scanning the bar code labels below to check your data formatting.



12/5 056876



12/5 087987

STATUS CHECK

SCANTEAM 2000 Programming Menu

2000/C

When a Status Check of the 2000/C programmed parameters is requested, it will be presented in the following format. The example illustrates decoded parameters configured to their DEFAULT values:

```
3593-01 Rev. 2.0
(C)COPYRIGHT BY WELCH ALLYN 1992
  ID : 03
  BEEPER : 1919
  KB STYLE : 00
KB LAYOUT : 00
  IC DLY : 00 00
  IF DLY : 00 00
  IM DLY : 00 00
  PREAM : FF
  POSTAM : FF
MULT SCAN : Y
  INHIBIT : N
  CODE TX : M
  FUN TX : Y
  LASER T/O : Y
  LAS REDUN : Y
  DUAL WAND : N
  CNTRY CDE : 00
  TERM : 01, 02, 03, 04 ....
```

```
3593-01 Rev. 2.0
(C)COPYRIGHT BY WELCH ALLYN 1992
  FORMT REQ : N
  DAT FORMT : FF
  MSR DATA : N N
  MSR TRK : Y Y
  MSR TRK2 : 00
  MSR TRK1 : 00
  KEY CODE1 : 0D
  KEY CODE2 : 0D
  KEY CODE3 : 0D
  KEY CODE4 : 0D
```

2000/R

The Status Check of the programmed parameters of a 2000/R uses only choice D (Software Revision) on the Status Check menu page. Choice D displays the software revision number, 33592XXX, where "XXX" stands for the version level. After the Software Status is transmitted (printed out), you will automatically exit programming mode (no need to scan the EXIT code).



USE THIS PAGE

- To output the current programming status of menu pages to either the terminal or the auxiliary port.





ENTER

selections		variables	
TO TERMINAL	I	Operating Parameters (2000/C ONLY)	A
		N/A	B
		Formats	C
		Software Revision (2000/R ONLY)	D
TO AUXILIARY	II	Operating Parameters (2000/C ONLY)	A
		N/A	B
		Formats	C
		Software Revision (2000/R ONLY)	D



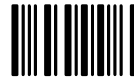

EXIT

KEYBOARD LAYOUTS

NCR 2152/27–Key

A0	A5	A6	A7	C8
A1			A8	C9
A2			A9	D0
A3			B0	D1
A4				D2

NCR 2152/50–Key

A0	A6	B2	B8	C0	C2	C7	D3
A1	A7	B3	B9	C1	C3	C8	D4
A2	A8	B4			C4	C9	D5
A3	A9	B5			C5	D0	D6
A4	B0	B6			C6	D1	D7
A5	B1	B7				D2	D8

NCR 2151/27–Key and 32–Key

B6	A0	A5	A6	A7	B1
B7	A1			A8	B2
B8	A2			A9	B3
B9	A3			B0	B4
C0	A4				B5

NCR 7052/32–Key and 56–Key

C2	C5	C8	D1	D4	D7	E0
C3	C6	C9	D2	D5	C8	E1
C4	C7	D0	D3	D6	D9	E2
A0	A5	B0	B1	B2	B7	E3
A1	A6			B3	B8	E4
A2	A7			B4	B9	E5
A3	A8			B5	C0	E6
A4	A9			B6	C1	E7

IBM 3683/48–Key

	A0	A4	A8	B3	B8	B9	C0	C4	C8
	A1	A5	A9	B4			C1	C5	C9
	A2	A6	B0	B5			C2	C6	D0
	A3	A7	B1	B6			C3	C7	D1
			B2	B7					

IBM 3653/30–Key and 3683/35–Key

		A7	A8	A9	B5	
	A0	A1		B0	B3	B6
	A2	A3		B1	B4	B7
	A4	A5		B2		B8
		A6				

IBM 3683/52–Key

	A0	A4	A8	B3	B8	B9	C0	C4	C8
	A1	A5	A9	B4			C1	C5	C9
	A2	A6	B0	B5			C2	C6	D0
	A3	A7	B1	B6			C3	C7	D1
	D5	D4	B2	B7				D3	D2

Notes: (1) Keyboard layouts and delimiter designations for both the 3653 30 Key and 3683 35–Key keyboards are the same except the far left column of five keys does not exist on the 3653.

Welch Allyn  SCANTEAM 2000 Programming Menu **KEYBOARD LAYOUTS**
Continued

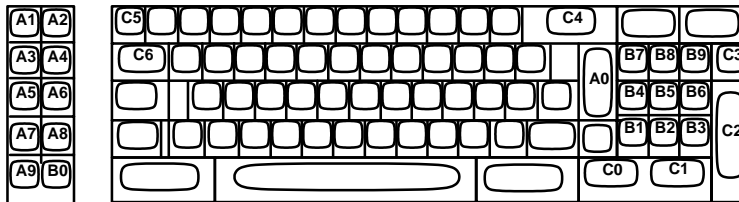

IBM XT Keyboard

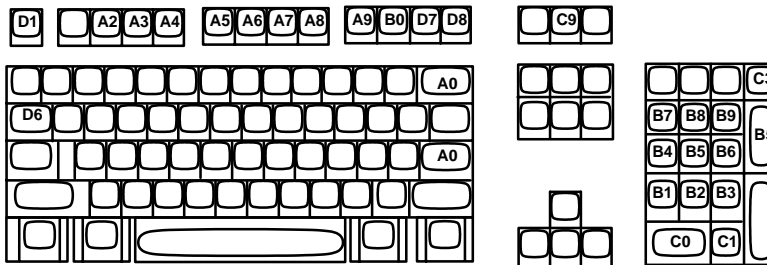

IBM PC/AT Keyboard

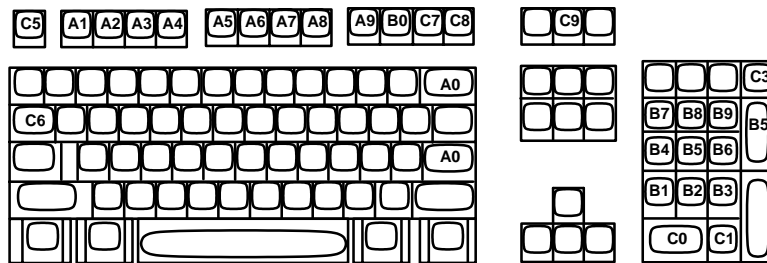

IBM PS2-30 Keyboard

KEYBOARD LAYOUTS

Continued

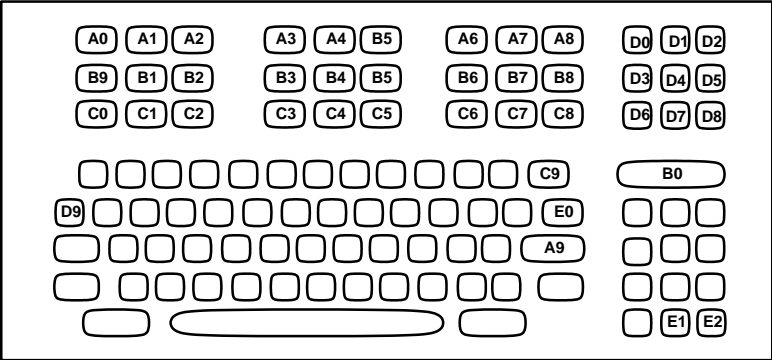

NCR 2950 Keyboard

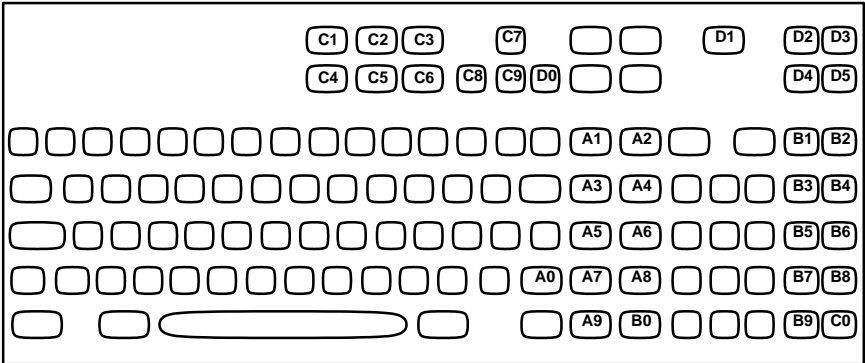

NCR 7052 122 Keyboard

- The FO delimiter translates to the following:
- | | |
|-------------------------------|----------------|
| NCR 2151/52, 27/32 key layout | ENTER KEY = B0 |
| NCR 2950, alpha/num layout | ENTER KEY = B0 |
| NCR 2152, 50 key layout | ENTER KEY = C6 |
| NCR 7052, 32/56 key layout | ENTER KEY = B6 |
| NCR 7052, 122 Big Ticket | ENTER KEY = B9 |
| IBM 3653/83, 30/35 key layout | ENTER KEY = B2 |
| IBM 3683, 48/52 key layout | ENTER KEY = C3 |

Welch Allyn  SCANTEAM 2000 Programming Menu **KEYBOARD LAYOUTS**
Continued

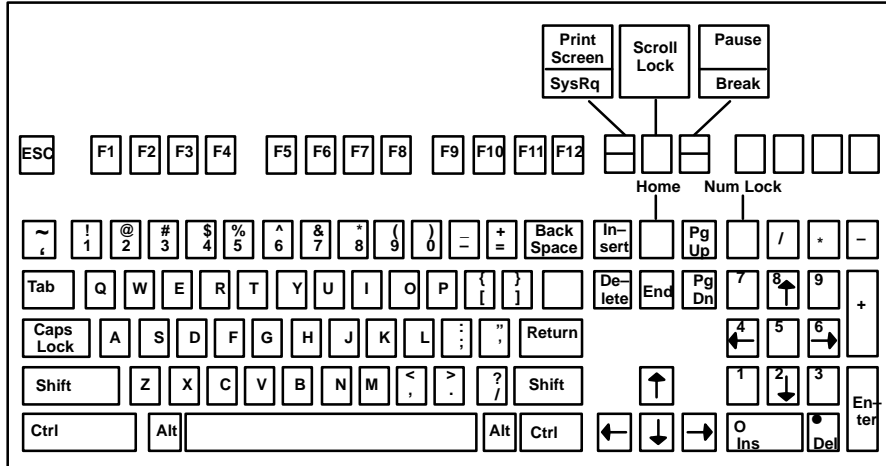

Enhanced PC Style WYSE ID=18

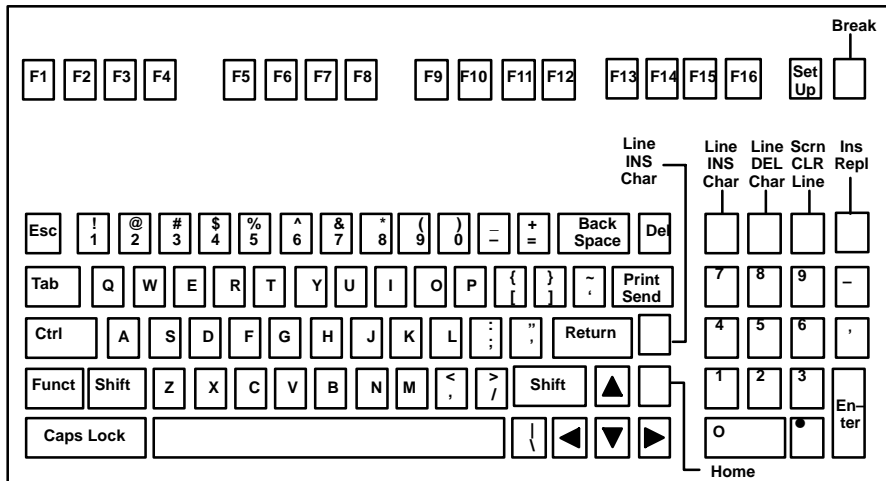

**General Purpose ASCII/ANSI Style
WYSE 60/120, 150 ASCII = 14 ANSI = 15**

The SCANTEAM 2000 Series Programming Menu is used to program both the 2000R(etail) and the 2000C(ommerical) Decoders. The following chart lists the defaults for each of the selections. The 2000/C/R column lists the common defaults. The defaults for the 2000/C and the 2000/R are listed under the appropriate heading.

Selections	Defaults		
	2000/C/R	2000/C	2000/R
OUTPUT PARAMETERS			
Beeper Tone/Volume	1919		
Keyboard Style	A		
Keyboard Layout			Layout 1 (Telephone)
4683 I/O Port Selection			Port 5B
OCIA Format selection			NCR 'S'
OCR Format Selection			Fujitsu
Intercharacter Delay	0000		
Interfunction Delay	0000		
Intermessage Delay	0000		
Preambles	00		
Postamble	00		
Output Modes			
Buffer Scans		Yes	No
Input Inhibit	No		
Code ID Transmit	No		
Function Code Transmit		Yes	No
OCIA and Wedge			No
IBM 4680 Dual Track MSR Tr.1/2			No
IBM 4680 Dual Track MSR Tr. 2/3			No
AIM ID		No	
Scanner Port ID		No	
Wand/Laser Port Modes			
Hand Held Laser Timeout	Yes		
Laser Redundacy		Yes	No
Dual Wand		Yes	No
Constant Scann CCD	No		
Hands-Free Stand Timeout			C5C1
Country Code			
United States	00		
CODE SELECTION (INDUSTRIAL)			
Codabar			
Enable		Yes	No
Minimum Length	01		
Maximum Length	60		
S/S Xmit	No		
Check Char. Required	No		
Xmit Check Char.	No		
Concatenaation		Yes	No
Concatenation Required	No		
Code 39			
Enable	Yes		
Minimum Length	00		
Maximum Length	48		
S/S Xmit	No		
Check Char. Required	No		
Xmit Check Char.	No		
Full ASCII	Yes		
Append Option	No		
Interleaved 2 of 5			
Enable		Yes	No
Minimum Length	04		
Maximum Length	80		
6, 14, & 16 Only	No		
Check Digit Required	No		
Xmit Check Digit	No		

DEFAULTS
continued

Selections	2000/C/R	Defaults 2000/C	2000/R
CODE SELECTION (INDUSTRIAL), continued			
Code 2 of 5			
Enable		Yes	No
Minimum Length	04		
Maximum Length	48		
Matrix 2 of 5			
Enable		Yes	No
Minimum Length	04		
Maximum Length	80		
S/S Xmit	No		
Code 11			
Enable		Yes	No
Minimum Length	04		
Maximum Length	80		
2 Check Digits (N=1)	Yes		
Code 93			
Enable		Yes	No
Minimum Length	00		
Maximum Length	64		
Code 128			
Enable	Yes		
Minimum Length	00		
Maximum Length	80		
EAN-128			
Enable	No		
Minimum Length	00		
Maximum Length	80		
ISBT-128			
Enable	No		
Code 16K			
Enable		Yes	No
Minimum Length	00		
Maximum Length	154		
Disable All Codes	No		
Decoding Algorithm			
Codabar	Yes		
Code 3 of 9	Yes		
Code 2 of 5		No	Yes
CODE SELECTION (RETAIL)			
UPC			
Version A	Yes		
Version D	No		
Version E0	Yes		
Check Digit Xmit		Yes	No
Number System Xmit		Yes	No
Version E Expand	No		
2-Digit Addenda	Yes		
5-Digit Addenda	Yes	No	
EAN			
EAN/JAN 13	Yes		
EAN/JAN 8	Yes		
Check Digit Xmit		Yes	No
2-Digit Addenda	Yes		
5-Digit Addenda	Yes		
UPC & EAN			
Enable	No		
MSI			
Enable		Yes	No
Minimum Length	04		
Maximum Length	48		
Plessey			
Enable		Yes	No
Minimum Length	04		
Maximum Length	48		
UPC & EAN Addenda Format			
With space	Yes		

Selections	Defaults		
	2000/C/R	2000/C	2000/R
AUXILIARY PORT 1			
Baud Rate	9600 – F	Even	Odd
Parity		Seven Bits	
Data Length		Record	EOR Char
Protocol		00	
Start of Record Char.			
End of Record	OD		
Start of Block		00	
End of Block Char.		04	
Function Codes		Yes	
CTS Check (Transmit)			No
4683 Async Address			Async Port Disable
DATA FORMATTER			
Format Required	No		
MSR Data			
Stop/Start Char. Transmit		No	Yes
LRC Char. Transmit		No	Yes
MSR Track Selection			
Track 1 Enable	Yes		
Track 2 Enable	Yes		
Track 3 Enable	Yes		
Key Code 1–4 Assignment			
Key Code 1 (E0H)	OD		
Key Code 2 (E1H)	OD		
Key Code 3 (E2H)	OD		
Key Code 4 (E3H)	OD		

USE THIS PAGE

■ For Scanner Port Entry Programming.



/C00

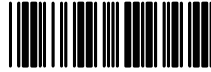

/C01



/C02



/C03



/C04

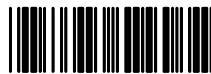

/C05



/C06



/C07



/C08



/C09



/C10



/C11



/C12



/C13



/C14



/C15



/C16



/C17



/C18



/C19



/C20



/C21



/C22

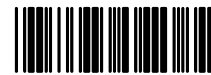

/C23



/C24

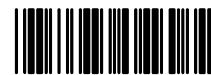

/C25

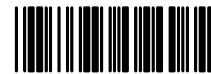

/C26

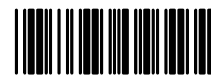

/C27

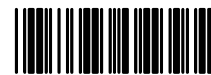

/C28



/C29



/C30



/C31

USE THIS PAGE

- In combination with the adjoining menu pages to program the 2000.
- The bar codes on this page correspond to symbols in shaded areas on adjoining menu pages. SCAN these bar codes in the sequence indicated on menu page to program desired selections and variables.

ROMAN NUMERALS



I



II



III



IV



V



VI



VII



VIII



IX



X



XI



XII



XIII



XIV



XV



XVI



XVII



XVIII



XIX



XX

LETTERS



A



B



C



D



E



F



G



H



I



J

DIGITS



0 (YES)



1 (NO)



2



3



4



5



6



7



8



9

OTHERS



ESCAPE



DEFAULT



EXIT



ALT-A

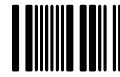

ALT-B

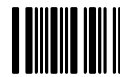

ALT-C

SAMPLE BAR CODES

SCANTEAM 2000 Programming Menu

■ This page contains bar code symbols in some of the most commonly used symbologies. You may use these codes to test that your system is properly programmed for a particular symbology.

UPC-A

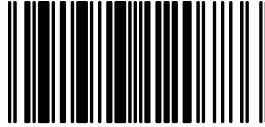

0-3132312078-6

UPC-A

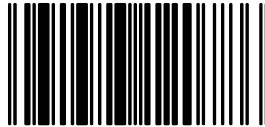

0-3132312078-6

5 add on

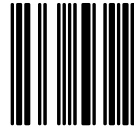

56098

EAN-13

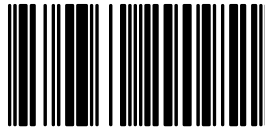

97-8033029095-1

Code 128



CODE 128

Interleaved 2 of 5

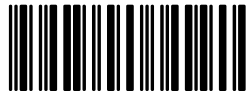

1234567890

Codabar



B-:/.+00012B

Code 3 of 9

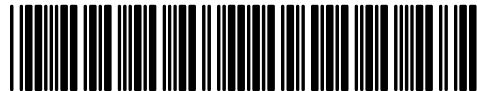

TEST-SHEET



Welch Allyn



2000/PM Rev M