

SCANTEAM[®]

3000/PDF

PDF417 Capable CCD
Reader

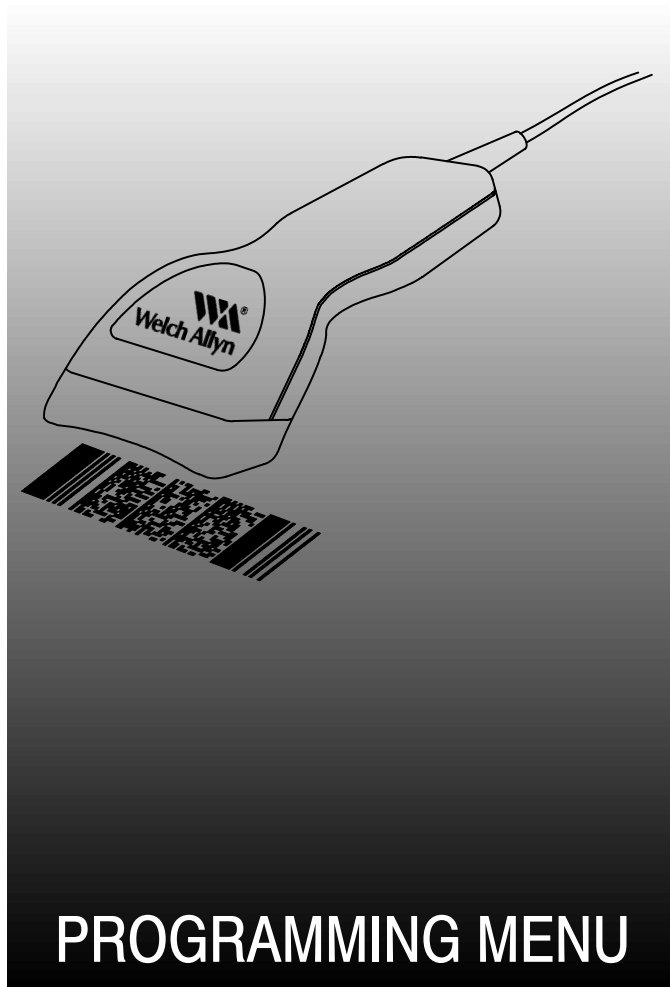

PROGRAMMING MENU



© 1998 Welch Allyn, Inc. All rights reserved.

The SCANTEAM 3000/PDF Programming Menu is used to program the 3000 Decoded Output PDF417 Capable CCD Reader.

The SAMPLE BAR CODES page (near the end of the programming menu) contains bar code symbols that you may use to verify that you have programmed your SCANTEAM 3000/PDF correctly.

Input Power Voltage Requirements	
<u>Model</u>	<u>Input Power Voltage</u>
3000-X3	5 Volt or 12 Volt
3000-X2 3000-X4	5 Volt ONLY 

Disclaimer

Welch Allyn® reserves the right to make changes in specifications and other information contained in this document without prior notice, and the reader should in all cases consult Welch Allyn to determine whether any such changes have been made. The information in this publication does not represent a commitment on the part of Welch Allyn.

Welch Allyn shall not be liable for technical or editorial errors or omissions contained herein; nor for incidental or consequential damages resulting from the furnishing, performance, or use of this material.

This document contains proprietary information which is protected by copyright. All rights are reserved. No part of this document may be photocopied, reproduced, or translated into another language without the prior written consent of Welch Allyn, Incorporated.

USE THIS PAGE

■ As a general overview of the programming menu. The programming menu consists of two basic components as shown below.

Welch Allyn  Programming Menu **CODE SELECTION II (RETAIL)**

USE THIS PAGE
 ■ To select the one (programmed, asterisked (*) values) by scanning DEFAULT symbol.
 ■ To enable or disable listed code selections.

selections	scan	variables	scan	scan
UPC ID = c (HEX 63)	I	Version A Version D(2) Version E(1) Check Digit Xmit Number System Xmit Version E Expand 2-Digit Addenda 5-Digit Addenda	A B C D E F G H I	*Yes/No No *Yes/No *Yes/No *Yes/No *Yes/No *Yes/No *Yes/No
EAN ID = d (HEX 64)	II	EAN/JAN 13 EAN/JAN 8 Check Digit Xmit 2-Digit Addenda 5-Digit Addenda	A B C D E	*Yes/No *Yes/No *Yes/No *Yes/No *Yes/No
UPC & EAN Addenda Req'd.	III	Enable		Yes/No
HSI ID = g (HEX 67)	IV	Enable Minimum Length Maximum Length	A B	*Yes/No 04-Max Min-8B
Plessey ID = h (HEX 6E)	V	Enable Minimum Length Maximum Length	A B	*Yes/No 04-Max Min-8B
DISABLE ALL CODES (3)	X	Are you sure?		Yes/No

Notes:
 (1) * Designates DEFAULT selections.
 (2) UPC Version D is not supported at this time.
 (3) This option includes all industrial and stacked symbologies.

ENTER
DEFAULT
ESCAPE
EXIT

SAMPLE MENU PAGE

Welch Allyn  Programming Menu **BAR CODE CHART II**

USE THIS PAGE
 ■ In combination with the adjoining menu pages to program the unit.
 ■ The bar codes on this page correspond to symbols in shaded areas on adjoining menu pages. SCAN these bar codes in the sequence indicated on menu page to program desired selections and variables.

DIGITS

0 (YES) 5
1 (NO) 6
2 7
3 8
4 9

OTHERS
ESCAPE DEFAULT EXIT

BAR CODE CHART

MENU PAGE

- Each menu page represents one section of the programming menu. Use individual menu pages in combination with the bar code chart on the back page foldout to program the decoder.
- **USE THIS PAGE** – A summary of the programming options (parameters) of each menu page.
- **ENTER** – Each menu page has its own unique ENTER bar code; scan this bar code to activate desired menu page.
- **DEFAULT** – The DEFAULT bar code allows the user to independently default menu pages to asterisked (*) values without affecting, in any way, the rest of the programming menu. Default values can be easily selected from the desired menu pages by scanning the bar code sequence ENTER, DEFAULT, EXIT. Individual defaults for a specific selection can be made by scanning ENTER, ROMAN NUMERAL, DEFAULT, EXIT.
- **ESCAPE** – Use this bar code to cancel current programming sequence. All parameters remain as they were. Scan ESCAPE to abort changes and exit from programming mode.
- **EXIT** – Scanning this bar code ends programming selection. Go from one menu page to another by scanning a new ENTER code (no need to scan EXIT between pages). Scan EXIT to save changes and end programming sequence.
- **SELECTIONS/VARIABLES** – Lists all of the options available on each menu page. Following each option are symbols in shaded areas. These symbols correspond to bar codes on the adjoining bar code chart.
- **NOTES** – are provided to call out any unusual situations and/or refer you to necessary information or examples elsewhere in the menu or manual.

Programming Note: Programming changes are in effect as soon as you make them! For example: changes to the beeper volume can be heard instantly. Likewise, changes to the baud rate parameters occur as soon as the "ENTER RS-232," Roman Numeral "I," and number ("0-6") sequence has been scanned. EXIT will save the changes; ESCAPE will restore the original settings. Take care that programming parameters match your terminal settings.

MENU PAGE FACING (Not Shown)

- The page facing the menu is often used to supplement or clarify the material presented on the front of each menu page. The information and examples found here are specific to the individual menu page and contain, in some cases, charts and diagrams that must be used in order to determine the correct programming sequence.

BAR CODE DATA CHART

- The bar codes on this chart are assigned to a ROMAN NUMERAL, LETTER, DIGIT, OR YES/NO symbol. These bar codes correspond to the symbols in shaded areas on the menu pages and are scanned in various combinations to enter programming sequences to the decoder. Bar codes on this page are meaningless unless an ENTER bar code from one of the menu pages is first scanned. When an ENTER bar code is scanned, the bar code chart becomes specific to that menu page and remains so until the EXIT bar code is scanned or another menu page is selected.

BEEPER

Volume

This programming selection provides control of the reader's beeper volume. The beeper volume may be set from low to high in four increments. Default = "2," medium-high.

Beep on Power Up

When enabled, the reader will double beep each time the system is reset. When disabled, the beeper will not sound whenever the system is reset. Default = enabled ("Yes").

Beep on Good Read

When enabled, the reader will beep once following a successful decode. When disabled, the beeper will not sound following the decode. Default = enabled ("Yes").

Code 16K, Code 49: Click on Row Read

When enabled, the reader will click once after each row of a Code 16K or Code 49 stacked bar code has been read. When disabled, the beeper will not sound after scanning rows of Code 16K or Code 49 stacked bar code. Default = disabled ("No").

PDF417: Ticking Indicates Scanning Progress

When enabled, the reader will emit a ticking sound as it scans a PDF417 symbol. The rate of ticking is proportional to the rate of data collection. When disabled, the beeper will not sound while scanning a PDF417 symbol. Default = disabled ("No").

PDF417: Humming Indicates Decoder Is Busy

When enabled, the reader will emit a humming sound while it is decoding a PDF417 symbol. When disabled, the beeper will not sound while decoding a PDF417 symbol. Default = enabled ("Yes").

What the Beeper is Telling you:	
As audible feedback, the PDF Capable reader provides six different beeps: single beep, double beep, triple beep, click, tick, and hum.	
Single Beep	One beep signals a successful barcode read.
Double Beep	Two beeps in succession indicate either: <ul style="list-style-type: none">• a hardware reset (as when the unit is first powered on)• ENTER/EXIT/ESCAPE programming mode (when using the programming menu pages).
Triple Beep	Three quick beeps in succession indicate an error condition, as when an illegal menu code is scanned, or when the serial input buffer overflows. Every character sent to the PDF Capable reader is stored in a buffer. If the characters arrive faster than the reader can process them, it is possible (though rare) that the input buffer will completely fill up, and an overflow occurs. See Technical Manual for more details.
Click	A "Click" has the same pitch as a beep, but has a much shorter duration. The click signals a successful row read for stacked codes 16K and 49. This provides useful feedback when the codes are scanned using a wand. Such feedback may not be as useful when using PDF Capable readers, since they have been optimized to read stacked codes.
Tick	The "Tick" has the shortest duration, and no perceivable pitch. It is used to indicate scanning progress while reading PDF417. A tick is initiated for every 32 PDF417 codewords read. A high rate of ticking corresponds to a high rate of data collection, thus good printing and good scanning technique are indicated by a high ticking rate. <i>Refer to the PDF Technical manual for printing/scanning suggestions. In general, keep the scan line of the reader aligned with the rows of the symbol. Printing smaller X-dimension and larger Y-dimension (row height) aids scanning ability.</i>
Hum	The "Hum" is a steady tone with a lower pitch and volume than the beep, and a variable duration. The PDF417 reader can't scan while decoding PDF417. When a great deal of error correction is required, the reader may appear to be "locked up." Humming indicates that the reader is busy decoding. Use the ticking option for PDF417 to learn how to scan for optimum performance. Careful scanning greatly decreases PDF417 decoding time.

BEEPER

USE THIS PAGE

- To default this page to asterisked (*) values.
- To set beeper volume.
- To program beep on power up and / or beep on good read.
- To program click on row read for Code 16K and Code 49.
- To program ticking or humming to indicate scanning / decoding progress for PDF417.

selections	scan	variables	scan
VOLUME	I	Low	0
		Medium-Low	1
		Medium-High	2*
		High	3
BEEP ON POWER UP	II	Enable	*Yes/No
BEEP ON GOOD READ	III	Enable	*Yes/No
CLICK ON ROW READ (Code 16K, Code 49 only)	IV	Enable	Yes/No*
TICKING INDICATES SCANNING PROGRESS (PDF417 only)	V	Enable	Yes/No*
HUMMING INDICATES DECODER IS BUSY (PDF417 only)	VI	Enable	*Yes/No



Notes:

(1) * Denotes DEFAULT variables.



RS-232

SCANTEAM 3000/PDF Information/Examples

Baud Rate

This programming selection sets the baud rate from 600 bits per second to 38,400 bits per second. Programming baud rate causes the data to be sent at the specified rate. Default = 9600 bits per second.

Character Format

This programming selection allows you to set the character format for number of data and parity bits. PDF capable products support seven or eight bits of data and zero or one parity bit per character. The number of start and stop bits is fixed at one each. If an application requires only ASCII characters 0 through 127 decimal (text, digits, and punctuation), select 7 data bits. For applications requiring use of the full ASCII set, select 8 data bits per character. Default = eight data bits, no parity, and one stop bit.

***Note:** PDF417 data is checked for accuracy before it is transmitted. This doesn't guarantee that errors won't be introduced during data communication. A parity bit may be added to each transmitted character as a means of character validation. A checksum character may also be added to the message as a postamble (suffix), for even stronger security (see Preamble/Postamble menu page). The receiving device must be set up for precisely the same character format as the reader, to ensure reliable communication.*

Data Flow Control

Flow control may be necessary to handle the larger PDF417 messages. The PDF417 reader will normally transmit a message immediately following a successful decode. With flow control selected, the receiver can enable/disable the reader's transmitter. Default = "None," no data flow control option selected.

For example: suppose the receiver stores transmitted characters in a 512-byte buffer, yet the PDF417 reader has a 1400-byte message to transmit. The receiver might take 510 characters into its buffer, then tell the reader to STOP transmitting. As the receiver processes the message, space becomes available in the 512-byte buffer and the receiver can tell the reader to START transmitting again.

Two methods of flow control have been implemented in the PDF capable products: RTS/CTS hardware handshaking, and an XON/XOFF protocol.

RTS/CTS Handshaking

This option will use two wires connected to both the reader and the receiver. The reader will have control of the RTS line, the receiver controls the CTS line.

Whenever the reader has a message to send, it will raise (the voltage on) the Ready To Send (RTS) line. (If the reader has no messages to send it will ground the RTS line.) When the receiver wants to suspend transmission it should ground the CTS line. The reader looks at the state of CTS prior to sending each character. When the receiver is willing to accept a message from the reader it should raise (the voltage on) the Clear To Send (CTS) line. The reader will resume sending messages, continuing where it left off when the CTS line was grounded.

XON/XOFF Protocol

This option uses only the transmit/receive lines between the reader and the receiver.

When the receiver wants to suspend transmission, it will send the XOFF character (ASCII 19 decimal) to the reader. When the receiver wants to resume transmission, it will send the XON character (ASCII 17 decimal) to the reader. The reader will resume sending messages, continuing where it left off when the XOFF character was sent.

USE THIS PAGE

- To default this page to asterisk (*) values.
- To set baud rate.
- To program character format.
- To program data flow control.

selections	scan	variables	scan
BAUD RATE	I	600 bits/second	0
		1200 bps	1
		2400 bps	2
		4800 bps	3
		9600 bps	4*
		19200 bps	5
		38400 bps	6
CHARACTER FORMAT	II	7 Data, Space Parity, 1 Stop	0
		7 Data, Mark Parity, 1 Stop	1
		7 Data, Even Parity, 1 Stop	2
		7 Data, Odd Parity, 1 Stop	3
		8 Data, No Parity, 1 Stop	4*
		8 Data, Mark Parity, 1 Stop	5
		8 Data, Even Parity, 1 Stop	6
DATA FLOW CONTROL	III	None	0*
		RTS/CTS Handshaking	1
		XON/XOFF Flow Control	2

Notes:

(1) * Denotes DEFAULT variables.

scan



scan



scan



scan



TRIGGER

SCANTEAM 3000/PDF Information/Examples

Generally, a TRIGGER ON causes the reader to begin decoding, and a TRIGGER OFF halts decoding. The meaning of TRIGGER ON and TRIGGER OFF depends on the trigger mode.

Autotrigger Enable

In autotrigger mode, the reader scans continuously. It does not, however, output decoded messages continuously. Internal logic determines when to output a decoded message. This decision is based on several factors, including the state of TRIGGER ON/OFF. In the context of autotrigger mode, TRIGGER ON/OFF are defined as:

TRIGGER ON – The scanner senses the presence of several black/white elements (does not yet know if pattern is decodable).

TRIGGER OFF – The scanner senses the lack of black/white elements.

The reader's new autotrigger logic is aggressive, resulting in fast reads. It is *not* necessary to TRIGGER OFF in order to read a *new* code, but in order to reread the *same* code, one needs to TRIGGER OFF for about a quarter of a second.

Manual Trigger Enable

In manual trigger mode, a TRIGGER ON is required to activate scanning and decoding. In the context of manual trigger mode, TRIGGER ON/OFF are defined as:

TRIGGER ON – (A) The trigger switch is pressed *or* (B) The serial TRIGGER ON command (ASCII 18 decimal) is sent to the reader.

TRIGGER OFF – (A) The trigger switch is released *or* (B) The serial TRIGGER OFF command (ASCII 20 decimal) is sent to the reader.

In manual trigger mode it is necessary to TRIGGER OFF following a successful decode before another code can be read. The scanning stops immediately following a successful decode, but the reader is not TRIGGERED OFF until one of the conditions above has been satisfied.

Note: *If the scanner is triggered serially, it isn't necessary to send the TRIGGER OFF command.*

A power-saving mode is available for hand-held readers having a hardware trigger in manual trigger mode. All that is required is the proper cable. **(Contact your sales representative or refer to the IPWC Cable Matrix for hand-held CCD constant/switched-power cable information.)** On power-up, the reader senses if the unit is using the switched-power cable, and goes immediately into a low-power mode. Only the trigger-sensing circuitry is powered (current draw is ≈ 0.23 mA @ 5V for 3000-12C) until the trigger is pulled. Refer to the scanner's Technical Manual for specifics.

Note: *Manual Trigger mode is not available in hand-held scanners having no trigger switch (such as the 3000-0XC).*

TRIGGER

USE THIS PAGE

- To default this page to asterisk (*) values.
- To set the trigger mode to autotrigger.
- To set the trigger mode to manual trigger.

selections	scan
AUTOTRIGGER ENABLE	I*
MANUAL TRIGGER ENABLE <i>(For both hardware and serial triggering)</i>	II

Notes:

(1) * Denotes DEFAULT selection.



PREAMBLE/POSTAMBLE

Preamble/Postamble

The scanner will transmit the decoded message after every successful bar code read. You have the option of adding characters before (preamble) and after (postamble) the bar code:

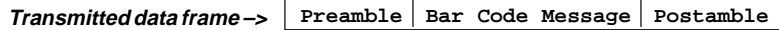

Characters for the preamble and postamble are selected by their hexadecimal ASCII value, up to 8 characters each. In addition, special characters are available for code identification and for error detection. Programming preamble/postambles is flexible, allowing creative framing possibilities.

These preamble/postambles apply to all messages regardless of the symbology, and cannot be assigned for a specific symbology. The special characters for Code ID **will** change to indicate the decoded symbology.

Note: *HEX-ASCII and Symbology charts are shown below the Preamble/Postamble Examples. Special Characters and their explanations are on following (menu) page.*

Preamble/Postamble Examples:

- The postamble defaults to a carriage return plus line feed:

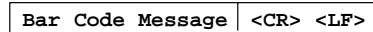

If no postamble is desired, scan:

ENTER, II, EXIT

Where: ENTER (Preamble/Postamble) enters programming mode.

II selects postamble programming and clears current postamble.

EXIT saves changes and exits programming mode.

- To frame a message with <STX> (start of transmission) and <ETX> (end of transmission):

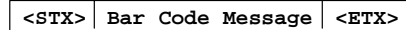

First program the preamble, then the postamble, by scanning:

ENTER, I, 0, 2, II, 0, 3, EXIT

Where: ENTER (Preamble/Postamble) enters programming mode.

I selects preamble programming and clears current preamble.

02 represents the hexadecimal ASCII value for the <STX> character.

II selects postamble programming and clears current postamble.

03 represents the hexadecimal ASCII value for the <ETX> character.

EXIT saves changes and exits programming mode.

HEX – ASCII CHART									
NUL 00	DLE 10	SP 20	0 30	@ 40	P 50	' 60	p 70		
SOH 01	DC1 11	! 21	1 31	A 41	Q 51	a 61	q 71		
STX 02	DC2 12	" 22	2 32	B 42	R 52	b 62	r 72		
ETX 03	DC3 13	# 23	3 33	C 43	S 53	c 63	s 73		
EOT 04	DC4 14	\$ 24	4 34	D 44	T 54	d 64	t 74		
ENQ 05	NAK 15	% 25	5 35	E 45	U 55	e 65	u 75		
ACK 06	SYN 16	& 26	6 36	F 46	V 56	f 66	v 76		
BEL 07	ETB 17	' 27	7 37	G 47	W 57	g 67	w 77		
BS 08	CAN 18	(28	8 38	H 48	X 58	h 68	x 78		
HT 09	EM 19) 29	9 39	I 49	Y 59	i 69	y 79		
LF 0A	SUB 1A	* 2A	: 3A	J 4A	Z 5A	j 6A	z 7A		
VT 0B	ESC 1B	+ 2B	; 3B	K 4B	[5B	k 6B	{ 7B		
FF 0C	FS 1C	, 2C	< 3C	L 4C	\ 5C	l 6C	7C		
CR 0D	GS 1D	- 2D	= 3D	M 4D] 5D	m 6D	} 7D		
SO 0E	RS 1E	. 2E	> 3E	N 4E	^ 5E	n 6E	~ 7E		
SI 0F	US 1F	/ 2F	? 3F	O 4F	_ 5F	o 6F	DEL 7F		

SYMBOLGY CHART								
Symbology	Code ID	ASCII	Symbology	Code ID	ASCII	Symbology	Code ID	ASCII
Codabar	a	61	Industrial 2 of 5	f	66	Code 49	l	6C
Code 39	b	62	MSI code	g	67	Matrix 2 of 5	m	6D
UPC	c	63	Code 11	h	68	Plessey code	n	6E
EAN	d	64	Code 93	i	69	Code 16K	o	6F
Interleaved 2 of 5	e	65	Code 128	j	6A	PDF417	r	72

PREAMBLE/POSTAMBLE

USE THIS PAGE

- To default this page to asterisked (*) values.
- To program preamble/postamble variables.

selections		variables
PREAMBLE (Prefix)	I	Up to EIGHT hexadecimal pairs, 00 through FF
POSTAMBLE (Suffix)	II	Up to EIGHT hexadecimal pairs, 00 through FF



Notes:

- (1) DEFAULT is **NO** preamble and **<CR> <LF>** postamble.

Special Characters

Hex Character	Result
80	<p>Insert Code ID</p> <p>The 80 hex will be replaced by a single character identifying the decoded barcode symbology. <i>See the Symbology Chart, facing page.</i></p>
81	<p>Insert AIM Symbology ID and Modifier</p> <p>The 81 hex will be replaced by a three character string:]CM</p> <p><i>Where:</i>] is the symbology ID flag character C is the symbology ID character M is the modifier character</p> <p><i>See AIM Guidelines on Symbology Identifiers for more information.</i></p>
85	<p>Insert LRC Checksum as two printable hexadecimal characters plus a space</p> <p>When placed at the end of a transmitted message, the LRC checksum provides a modest amount of error detection. The checksum is computed as the Exclusive-Or of every transmitted character, after being initialized to zero.</p> <p>The LRC checksum can have any value 00 through FF hexadecimal, but not all characters in this range are printable. This option causes the LRC checksum to be transmitted as three characters; two hexadecimal numbers plus a space.</p>
86	<p>Insert LRC Checksum as a single byte</p> <p>A single character is transmitted having a value 00 through FF hexadecimal.</p>
87 XX	<p>Set LRC Checksum = XX (hexadecimal)</p> <p>For initializing the checksum to some value other than zero, XX can be any value 00 through FF hexadecimal.</p>



CODE SELECTION I (INDUSTRIAL)

SCANTEAM 3000/PDF Information/Examples

Note: Welch Allyn PDF Capable readers can autodiscriminate between 15 Symbologies. For maximum data security, disable the codes not used.

Symbology	Option	Explanation
Codabar	S/S Xmit	Data in a Codabar symbol is framed by a start and a stop character. Since they are not considered part of the message, they are not ordinarily transmitted.
	Check Char Req'd	For applications requiring enhanced security, a check character may be used. When enabled, the reader will assume that the last character is a check character, and will use it to verify the accuracy of the scanned data. If no error is detected, the data will be transmitted.
	Xmit Check Char	When required, the check character will be verified, but will not normally be transmitted. Enable this option to transmit the checksum, when planning to verify transmitted data.
	Concatenation	Codabar provides an option for concatenating messages of adjacent symbols. The reader can distinguish those messages which are concatenated from those that are not. Select "NO" to prevent concatenation.
	Concatenation Req'd	With this option enabled the reader <i>only</i> responds to concatenated symbols. If a particular application will always use concatenation with Codabar, then this option is recommended.
Code 39	S/S Xmit	Data in a Code 39 Symbol is framed by a start and a stop character. Since they are not considered part of the message they are not ordinarily transmitted.
	Check Char Req'd	For applications requiring enhanced security, a check character can be used. When enabled, the reader will assume that the last character is a check character, and will use it to verify the accuracy of the scanned data. If no error is detected, the data will be transmitted.
	Xmit Check Char	When required, the check character will be verified, but will not normally be transmitted. Enable this option to transmit the checksum, when planning to verify transmitted data.
	Full ASCII	The code 39 specification provides a means of encoding the full ASCII set of characters by using two-character sequences made up of one of the four Code 39 characters (\$ + % /) followed by one of the 26 letters as shown in the Full ASCII Code 39 chart (on page 14). The reader cannot distinguish Code 39 labels encoded in full ASCII mode from those encoded in standard mode. Use this option to direct the decoder which mode to assume.
	Append Option	The Code 39 specification provides a means of appending data messages. If the first data character of a Code 39 symbol is a SPACE, then data following the SPACE can be appended to a storage buffer. PDF Capable readers don't have an append buffer; therefore this function isn't available. When append option is selected, any leading SPACE is removed from the transmitted message.
Interleaved 2 of 5	Check Digit Req'd	For applications requiring enhanced data security, a check character can be used. When enabled, the reader will assume that the last digit is a check digit, and will use it to verify the accuracy of the scanned data. If no errors are detected the data will be transmitted.
	Xmit Check Digit	When required, the check digit will be verified, but will not normally be transmitted. Enable this option to transmit the check digit, when planning to verify the transmitted data.
Code 11	Check Digits	The Code 11 specification recommends the use of two check digits. The PDF Capable reader may be programmed to read Code 11 symbols with only one check digit. The reader cannot autodiscriminate the number of check digits encoded in a symbol.

CODE SELECTION I (INDUSTRIAL)

USE THIS PAGE

- To select the pre-programmed asterisk (*) values by scanning DEFAULT symbol.
- To enable or disable listed code selections.

selections	scan	variables	scan	scan
CODABAR <i>ID = a (HEX 61)</i>	I	Enable		*Yes/No
		S/S Xmit	A	Yes/No*
		Check Char. Req'd	B	Yes/No*
		Xmit Check Char.	C	Yes/No*
		Concatenation	D	*Yes/No
		Concatenation Req'd	E	Yes/No*
CODE 39 <i>ID = b (HEX 62)</i>	II	Enable		*Yes/No
		S/S Xmit	A	Yes/No*
		Check Char. Req'd	B	Yes/No*
		Xmit Check Char.	C	Yes/No*
		Full ASCII	D	*Yes/No
		Append Option	E	Yes/No*
INTERLEAVED 2 OF 5 <i>ID = e (HEX 65)</i>	III	Enable		*Yes/No
		Check Digit Req'd	A	Yes/No*
		Xmit Check Digit	B	Yes/No*
CODE 2 OF 5 <i>ID = f (HEX 66)</i>	IV	Enable		*Yes/No
MATRIX 2 OF 5 <i>ID = m (HEX 6D)</i>	V	Enable		*Yes/No
CODE 11 <i>ID = h (HEX 68)</i>	VI	Enable		*Yes/No
		# Check Digits	A	
		2 Check Digits		*Yes
		1 Check Digit		No
CODE 93 <i>ID = l (HEX 69)</i>	VII	Enable		*Yes/No
CODE 128 <i>ID = j (HEX 6A)</i>	VIII	Enable		*Yes/No
DISABLE ALL CODES (2)	X	Are you sure?		Yes/No*



Notes:

- (1) * Denotes DEFAULT variables.
- (2) This option includes all retail and stacked symbologies.

CODE SELECTION II (RETAIL)

Note: Welch Allyn PDF Capable readers can autodiscriminate between 15 Symbologies. For maximum data security, disable the codes not used.

Symbology	Option	Explanation
UPC	Version A	Standard Version, used to encode a 12–digit number; the first digit is the number system character, the next ten are data characters, the last is a check character.
	Version D	This Variable–length version is not supported by the PDF Capable reader.
	Version E0	The zero–suppression version for number system 0 compacts UPC data into six digits.
	Version E1	No longer supported by the UPC specification because of its similarity to EAN 13, this zero–suppression version compacts UPC number system 1 data into six digits. The PDF Capable readers can be programmed to read UPC E1 as long as EAN 13 is disabled.
	Check Digit Xmit	The check digit of a UPC symbol is normally transmitted, though the reader can be programmed to suppress the check digit.
	Number System Xmit	The number system character of a UPC symbol is normally transmitted, though the reader can be programmed to suppress the check digit.
	Version E Expand	When this option is selected, the UPC E symbol is expanded into the standard 12–digit format.
	Addenda	Two / five digit addendas are supported; it is recommended you leave them disabled unless they are specifically required. If an addenda will always be used it is recommended you enable the UPC and EAN ADDENDA REQUIRED Option. When enabled, symbols without the addenda will not read.
EAN	EAN / JAN 13	A superset of UPC, EAN 13 encodes a 13–digit number; 12 data digits and a check digit.
	EAN / JAN 8	EAN encodes an 8–digit number; 7 data digits and a check digit.
	Check Digit Xmit	The check digit of an EAN symbol is normally transmitted, though the reader can be programmed to suppress the check digit.
	Addenda	Two / five digit addendas are supported; it is recommended you leave them disabled unless they are specifically required. If an addenda will always be used it is recommended you enable the UPC and EAN ADDENDA REQUIRED Option. When enabled, symbols without the addenda will not read.

FULL ASCII CODE 3 OF 9 CHART

NUL %U	DLE \$P	SP SPACE	0 0	@ %V	P P	' %W	p +P
SOH \$A	DC1 \$Q	! /A	1 1	A A	Q Q	a +A	q +Q
STX \$B	DC2 \$R	" /B	2 2	B B	R R	b +B	r +R
ETX \$C	DC3 \$S	# /C	3 3	C C	S S	c +C	s +S
EOT \$D	DC4 \$T	\$ /D	4 4	D D	T T	d +D	t +T
ENQ \$E	NAK \$U	% /E	5 5	E E	U U	e +E	u +U
ACK \$F	SYN \$V	& /F	6 6	F F	V V	f +F	v +V
BEL \$G	ETB \$W	' /G	7 7	G G	W W	g +G	w +W
BS \$H	CAN \$X	(/H	8 8	H H	X X	h +H	x +X
HT \$I	EM \$Y) /I	9 9	I I	Y Y	i +I	y +Y
LF \$J	SUB \$Z	* /J	:	J J	Z Z	j +J	z +Z
VT \$K	ESC %A	+ /K	; %F	K K	[%K	k +K	{ %P
FF \$L	FS %B	, /L	< %G	L L	\ %L	l +L	%Q
CR \$M	GS %C	- /M	= %H	M M] %M	m +M	} %R
SO \$N	RS %D	. /N	> %I	N N	^ %N	n +N	~ %S
SI \$O	US %E	/ /O	? %J	O O	_ %O	o +O	DEL %T

**CODE
SELECTION II
(RETAIL)**

USE THIS PAGE

- To select the pre-programmed asterisk (*) values by scanning DEFAULT symbol.
- To enable or disable listed code selections.

selections	scan	variables	scan	scan
UPC <i>ID = c (HEX 63)</i>	I	Version A	A	*Yes/No
		Version D (2)	B	No*
		Version E0	C	*Yes/No
		Version E1	D	*Yes/No
		Check Digit Xmit	E	*Yes/No
		Number System Xmit	F	*Yes/No
		Version E Expand	G	Yes/No*
		2-Digit Addenda	H	Yes/No*
		5-Digit Addenda	I	Yes/No*
EAN <i>ID = d (HEX 64)</i>	II	EAN/JAN 13	A	*Yes/No
		EAN/JAN 8	B	*Yes/No
		Check Digit Xmit	C	*Yes/No
		2-Digit Addenda	D	Yes/No*
		5-Digit Addenda	E	Yes/No*
UPC & EAN ADDENDA REQ'D.	III	Enable		Yes/No*
MSI <i>ID = g (HEX 67)</i>	IV	Enable		Yes/No*
PLESSEY <i>ID = n (HEX 6E)</i>	V	Enable		*Yes/No
DISABLE ALL CODES (3)	X	Are you sure?		Yes/No*



- Notes:**
- (1) * Denotes DEFAULT variables.
 - (2) UPC Version D is not supported at this time.
 - (3) This option includes all industrial and stacked symbologies.

**CODE
SELECTION III
(STACKED)**

Note: Welch Allyn PDF Capable readers can autodiscriminate between 15 Symbologies. For maximum data security, disable the codes not used.

Symbology	Option	Explanation
PDF417	One-Pass	If this option is enabled, any partial PDF417 scan will be cleared from memory upon a TRIGGER OFF. Normally PDF scans are saved in memory until either a DECODE or a new PDF417 label is scanned. It is not always possible for the reader to know when a new label is introduced.
	Notify-When-Certain	If this option is enabled, the reader sends out a message (ASCII decimal 23) to notify the host system that a successful PDF417 decode is certain; no more scanning is required. For Example: in a machine-mount system, a host computer moves a PDF417 label back and forth in front of the PDF Capable reader until the ASCII decimal 23 is received. At that point scanning is completed, and the decoded message will follow.
	When-To-Decode	The PDF Capable reader must temporarily halt scanning in order to perform PDF417 decoding. A refined algorithm automatically predicts when enough information has been scanned to insure a successful decode. If the scanned data contains many errors, though, decoding cannot succeed and more scanning is required. In a machine-mount system with a predetermined scan cycle, it may be an advantage to use Trigger-Off Decoding . When this option is enabled the reader will not attempt to decode PDF417 until a TRIGGER OFF. During the predetermined scanning time, the reader is sure to be collecting data.

Note: The PDF options were designed for machine-mount applications; however, they are available, but not recommended, for the hand held reader.

**CODE
SELECTION III
(STACKED)**

USE THIS PAGE

- To select the pre-programmed asterisk (*) values by scanning DEFAULT symbol.
- To enable or disable listed code selections.

selections	scan	variables	scan	scan
PDF417 <i>ID = r (HEX 72)</i>	I	Enable		*Yes/No
		One-Pass Option	A	Yes/No*
		Notify-When-Certain	B	Yes/No*
		When-To-Decode	C	
		Trigger-Off Decoding		0
		Automatic		1*
CODE 16K <i>ID = o (HEX 6F)</i>	II	Enable		*Yes/No
CODE 49 <i>ID = l (HEX 6C)</i>	III	Enable		*Yes/No
DISABLE ALL CODES (2)	X	Are you sure?		Yes/No*

Notes:

- (1) * Denotes DEFAULT variables.
- (2) This option includes all industrial and retail symbologies.



SERIAL MENU

Welch Allyn 

SCANTEAM 3000/PDF Programming Menu

Using the Serial Menu

The serial menu may be used any time in place of the bar code menuing. The serial menu is particularly useful for programming PDF capable machine-mount readers that don't have a hardware trigger.

Every programming menu code can be replaced by a two-character serial command. A serial device programs the reader by sending the proper sequence of serial commands. Use the menu pages to select the programming variables your application requires.

For every menu code, the equivalent two-character serial command (and its corresponding ASCII decimal value) are given in the SERIAL MENU CHARTS on the following pages.

Example 1

For instance, if you want PDF417 enabled and all other bar code symbologies disabled, use the CODES (STACKED) menu page. The correct sequence of serial commands would be:

F <Ctrl-X> T <Ctrl-Y> 0 <Ctrl-Y> K <Ctrl-Y> 0 <Ctrl-Y> <SPC> <Ctrl-Y>

The above serial commands correspond to the selections and variables on the programming menu page:

- ENTER code for that menu page
- "Disable All Codes" selection (Roman Numeral X)
- "Yes" (Digit 0) to disable all codes
- PDF417 selection (Roman Numeral I)
- "Yes" (Digit 0) to enable PDF417 decoding
- "EXIT" code for that menu page.

Example 2

If you wish to enable ticking to show PDF417 scanning progress, use the BEEPER menu page. The correct sequence of serial commands would be:

A <Ctrl-X> O <Ctrl-Y> 0 <Ctrl-Y> <SPC> <Ctrl-Y>

The above serial commands correspond to the selections and variables on the programming menu page:

- ENTER code for that menu page
- "Ticking Indicates Scanning Progress (PDF417)" selection (Roman Numeral V)
- "Yes" (Digit 0) to enable this selection
- "EXIT" code for that menu page.

Special Notes:

Take care not to confuse the letter O and the number 0. Note also that the DEFAULT code is represented by a period (.) followed by <Ctrl-Y>. ASCII (decimal) values are included on the SERIAL MENU CHARTS (below the corresponding serial command).

RS-232 parameter changes are immediately effected. The connected host serial device must also change to the programmed selections accordingly. After changing baud rate it may be necessary to wait a short amount of time for the serial port to stabilize. For this reason bar code menuing is suggested for changing RS-232 parameters.

In manual trigger mode, two serial commands may be used to turn the trigger on/off. The commands are:

ASCII 18 (decimal)	Ctrl-R	Trigger ON
ASCII 20 (decimal)	Ctrl-T	Trigger OFF

For PDF417, the notify-when-certain character is:

ASCII 23 (decimal)	Ctrl-W	Notify-When-Certain
--------------------	---------------	---------------------

USE THIS PAGE

- In combination with the adjoining menu pages to program the 3000/PDF by sending serial commands from the host.
- The serial command sequences on this page correspond to the bar code symbols on the BAR CODE CHARTS.

ROMAN NUMERALS

K <Ctrl-Y>
75 25

I

<- Serial Command ->
<- ASCII (decimal) ->

P <Ctrl-Y>
80 25

VI

L <Ctrl-Y>
76 25

II

<- Serial Command ->
<- ASCII (decimal) ->

Q <Ctrl-Y>
81 25

VII

M <Ctrl-Y>
77 25

III

<- Serial Command ->
<- ASCII (decimal) ->

R <Ctrl-Y>
82 25

VIII

N <Ctrl-Y>
78 25

IV

<- Serial Command ->
<- ASCII (decimal) ->

S <Ctrl-Y>
83 25

IX

O <Ctrl-Y>
79 25

V

<- Serial Command ->
<- ASCII (decimal) ->

T <Ctrl-Y>
84 25

X

ENTER CODES: MENU PAGES

A <Ctrl-X>
65 24

BEEPER

<- Serial Command ->
<- ASCII (decimal) ->

B <Ctrl-X>
66 24

RS-232

G <Ctrl-X>
71 24

TRIGGER

<- Serial Command ->
<- ASCII (decimal) ->

C <Ctrl-X>
67 24

PREAMBLE/POSTAMBLE

USE THIS PAGE

- In combination with the adjoining menu pages to program the 3000/PDF by sending serial commands from the host.
- The serial command sequences on this page correspond to the bar code symbols on the BAR CODE CHARTS.

LETTERS

A <Ctrl-Y>
65 25

A

<- Serial Command ->
<- ASCII (decimal) ->

F <Ctrl-Y>
70 25

F

B <Ctrl-Y>
66 25

B

<- Serial Command ->
<- ASCII (decimal) ->

G <Ctrl-Y>
71 25

G

C <Ctrl-Y>
67 25

C

<- Serial Command ->
<- ASCII (decimal) ->

H <Ctrl-Y>
72 25

H

D <Ctrl-Y>
68 25

D

<- Serial Command ->
<- ASCII (decimal) ->

I <Ctrl-Y>
73 25

I

E <Ctrl-Y>
69 25

E

<- Serial Command ->
<- ASCII (decimal) ->

J <Ctrl-Y>
74 25

J

ENTER CODES: MENU PAGES

D <Ctrl-X>
68 24

INDUSTRIAL CODES

<- Serial Command ->
<- ASCII (decimal) ->

E <Ctrl-X>
69 24

RETAIL CODES

F <Ctrl-X>
70 24

STACKED CODES

<- Serial Command ->
<- ASCII (decimal) ->

USE THIS PAGE

- In combination with the adjoining menu pages to program the 3000/PDF by sending serial commands from the host.
- The serial command sequences on this page correspond to the bar code symbols on the BAR CODE CHARTS.

DIGITS

0 <Ctrl-Y> 48 25	←- Serial Command → ←- ASCII (decimal) →	5 <Ctrl-Y> 53 25
0 (YES)		5
1 <Ctrl-Y> 49 25	←- Serial Command → ←- ASCII (decimal) →	6 <Ctrl-Y> 54 25
1 (NO)		6
2 <Ctrl-Y> 50 25	←- Serial Command → ←- ASCII (decimal) →	7 <Ctrl-Y> 55 25
2		7
3 <Ctrl-Y> 51 25	←- Serial Command → ←- ASCII (decimal) →	8 <Ctrl-Y> 56 25
3		8
4 <Ctrl-Y> 52 25	←- Serial Command → ←- ASCII (decimal) →	9 <Ctrl-Y> 57 25
4		9

OTHERS

* <Ctrl-Y> 42 25	←- Serial Command → ←- ASCII (decimal) →	<SPC> <Ctrl-Y> 32 25
ESCAPE		EXIT
. <Ctrl-Y> 46 25	←- Serial Command → ←- ASCII (decimal) →	
DEFAULT		

SAMPLE BAR CODES

SCANTEAM 3000 PDF Programming Menu

■ This page contains bar code symbols in some of the most commonly used symbologies. You may use these codes to test that your system is properly programmed for a particular symbology.

Code 39



TEST-SHEET

Interleaved 2 of 5



1234567890

Code 2 of 5



123456

Matrix 2 of 5

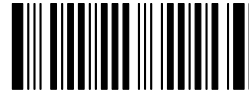

6543210

Plessey



9876

Codabar

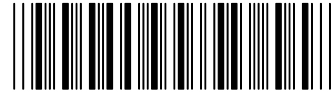

0013557900

Code 11



11223344

Code 128



CODE 128<BEL>

MSI



44332211

UPC-A

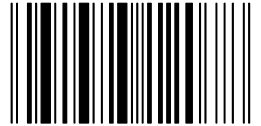

031323120786

5 add on

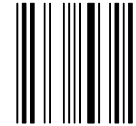

56098

EAN-13

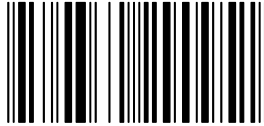

9780330290951

PDF417



WELCH ALLYN IS PDF CAPABLE!

USE THIS PAGE

- In combination with the adjoining menu pages to program the 3000/PDF.
- The bar codes on this page correspond to symbols in shaded areas on adjoining menu pages. SCAN these bar codes in the sequence indicated on menu page to program desired selections and variables.

ROMAN NUMERALS



ENTER CODES: MENU PAGES



USE THIS PAGE

- In combination with the adjoining menu pages to program the 3000/PDF.
- The bar codes on this page correspond to symbols in shaded areas on adjoining menu pages. SCAN these bar codes in the sequence indicated on menu page to program desired selections and variables.

LETTERS



ENTER CODES: MENU PAGES



USE THIS PAGE

- In combination with the adjoining menu pages to program the 3000/PDF.
- The bar codes on this page correspond to symbols in shaded areas on adjoining menu pages. SCAN these bar codes in the sequence indicated on menu page to program desired selections and variables.

DIGITS



0 (YES)



5



1 (NO)



6



2



7

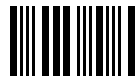

3



8

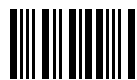

4



9

OTHERS



ESCAPE



EXIT



DEFAULT



3000/PDF/PM Rev B