

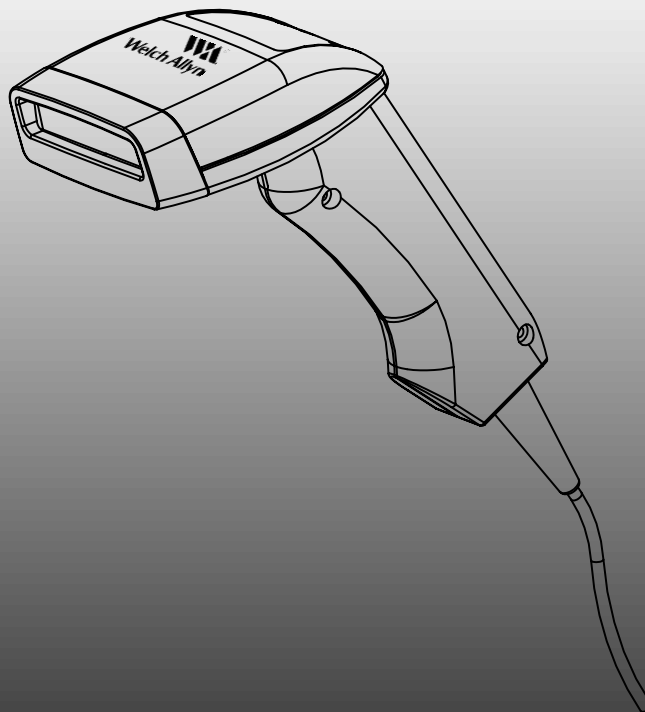

Welch Allyn ®
SCANTEAM® 3400 SERIES

Laser Emulation



USER'S GUIDE

© 1998 Welch Allyn, Inc. All rights reserved.

Input Power Voltage Requirements	
<u>Model</u>	<u>Input Power Voltage</u> 
3400-X0X 3400/X-X0X 3400LR/F-X0X	5 Volt <i>ONLY</i>

Disclaimer

Welch Allyn® reserves the right to make changes in specifications and other information contained in this document without prior notice, and the reader should in all cases consult Welch Allyn to determine whether any such changes have been made. The information in this publication does not represent a commitment on the part of Welch Allyn.

Welch Allyn shall not be liable for technical or editorial errors or omissions contained herein; nor for incidental or consequential damages resulting from the furnishing, performance, or use of this material.

This document contains proprietary information which is protected by copyright. All rights are reserved. No part of this document may be photocopied, reproduced, or translated into another language without the prior written consent of Welch Allyn, Incorporated.

This device complies with part 15 of the FCC Rules. Operation is subject to the following two conditions: (1) this device may not cause harmful interference, and (2) this device must accept any interference received, including interference that may cause undesired operation.

FCC Class B Compliance Statement

This equipment has been tested and found to comply with the limits for a Class B digital device pursuant to part 15 of the FCC Rules. These limits are designed to provide reasonable protection against harmful interference in a residential installation. This equipment generates, uses, and can radiate radio frequency energy and, if not installed and used in accordance with the instructions, may cause harmful interference to radio communications. However, there is no guarantee that interference will not occur in a particular installation. If this equipment does cause harmful interference to radio or television reception, which can be determined by turning the equipment off and on, the user is encouraged to try to correct the interference by one or more of the following measures:

- Reorient or relocate the receiving antenna.
- Increase the separation between the equipment and receiver.
- Connect the equipment into an outlet on a circuit different from that to which the receiver is connected.
- Consult the dealer or an experienced radio or television technician for help.

Caution: Any changes or modifications made to this device that are not expressly approved by Welch Allyn, Inc. may void the user's authority to operate the equipment.

Note: To maintain compliance with FCC Rules and Regulations, cables connected to this device must be *shielded* cables, in which the cable shield wire(s) have been grounded (tied) to the connector shell.

Canadian Notice

This equipment does not exceed the Class B limits for radio noise emissions as described in the Radio Interference Regulations of the Canadian Department of Communications. Le present appareil numerique n'emet pas de bruits radioelectriques depassant les limites applicables aux appareils numeriques de la classe B prescrites dans le Reglement sur le brouillage radioelectrique edicte par le ministere des Communications du Canada.



The CE mark on the product indicates that the system has been tested to and conforms with the provisions noted within the 89/336/EEC Electromagnetic Compatibility Directive and the 73/23/EEC Low Voltage Directive.

Welch Allyn shall not be liable for use of our product with equipment (i.e., power supplies, personal computers, etc.) that is not CE marked and does not comply with the Low Voltage Directive.

TABLE OF CONTENTS

Getting Started

<i>Section</i>	<i>Page</i>
Introduction to the 3400	3
Unpacking the Scanner	4
Scanner Identification	5
Connecting the Scanner	7
Scanning Techniques	9

Product Specifications and Pinouts

<i>Section</i>	<i>Page</i>
Environmental Specifications	11
Electrical Specifications	11
Scanner Performance	13
Pinouts	15
General Dimensions	16

Maintenance and Troubleshooting Guide

<i>Section</i>	<i>Page</i>
Maintenance	17
Troubleshooting	19

Customer Support

Limited Warranty

Sample Bar Codes (inside back cover)

GETTING STARTED

Introduction to the 3400

Note: *This document applies to the SCANTEAM 3400 Hand Held CCD and the SCANTEAM 3400 Long Range CCD unless otherwise noted.*

The SCANTEAM® 3400 Series CCD is durable and reliable, easy to hold and easy to aim. Featuring a unique optics design without moving parts or a glass mirror, the 3400:

- provides superior first read rate
- reads 5 mil code in close focus (3400–XX1) and 7 mil code at 3.5" (88.9 mm) (3400LR)
- reads 20 mil code from 0 to 4" [100mm] (3400–XX2) or 15 mil code from 0 to 6" [152.4 mm] (3400LR)
- scans bar code widths up to 3" [76mm] (3400) and up to 5" [127 mm] (3400LR).

The 3400 also offers low current consumption to extend the battery life of portable data terminals.

❖ About This Manual

This user's guide provides installation instructions for the Laser Emulation SCANTEAM 3400. Connector pinouts, product specifications, a troubleshooting guide, warranty and customer support information are also included.

Unpacking the Scanner

Open the carton. The shipping carton should contain:

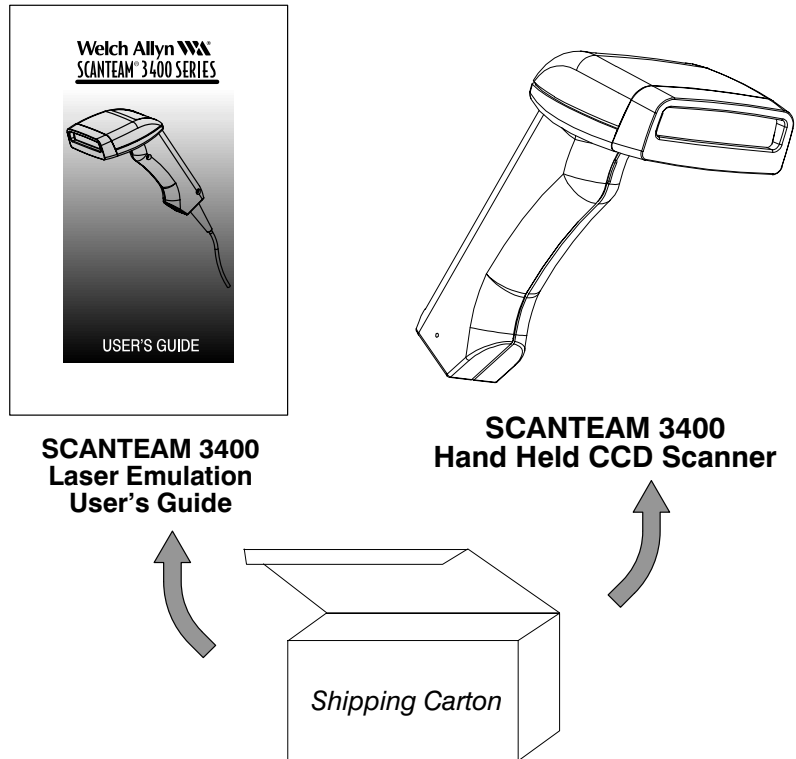

- Check to make sure everything you ordered is present.
- *Keep the shipping carton to return the scanner for servicing.*
- Check for damage during shipment. Report damage immediately to the carrier who delivered the carton.

Scanner Identification

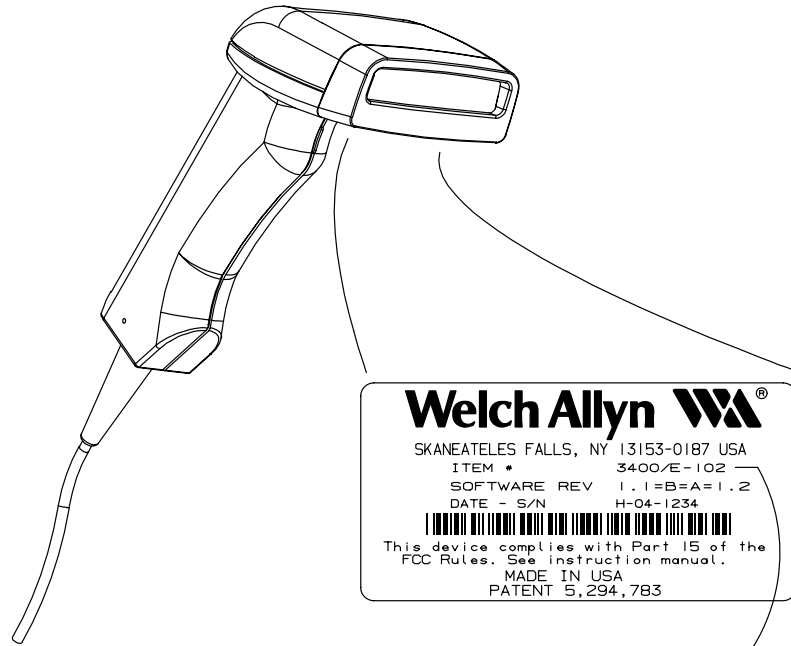

SCANTEAM 3400 Identification Label

Scan Rate ①
B = 100 Scans/Second
E = 50 Scans/Second

ITEM# 3400/E-102
① ②③④

Trigger Option ②
0 = Auto Trigger
1 = Manual Trigger

Focal Distance ④
1 = reads high density code in contact
2 = reads low density code from 0 to 4" [10cm]

Interface Option ③								
Option	IBM 4683	OCIA OCR	Bar Image Laser Out	Wand Emulation	TTL RS-232	True RS-232	Keyboard Wedge	RS-232 Wedge
0			•					
1	•	•	•	•	•		Various	
2		•	•	•	•		Various	
3						•	DEC Only	•

Scanner Identification (3400LR)

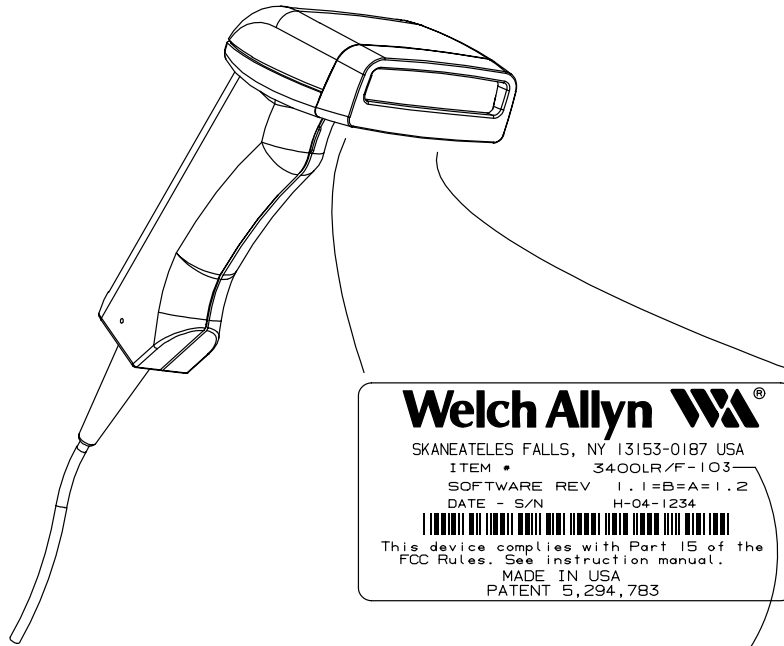

SCANTEAM 3400LR Identification Label

Scan Rate ①
F = 50 Scans/Second

ITEM# 3400LR/F-103
① ②③④

Trigger Option ②
1 = Manual Trigger

Focal Distance ④
3 = reads medium density codes from 0-6"

Interface Option ③								
Option	IBM 4683	OCIA OCR	Bar Image Laser Out	Wand Emulation	TTL RS-232	True RS-232	Keyboard Wedge	RS-232 Wedge
0			•					
1	•	•	•	•	•		Various	
2		•	•	•	•		Various	
3						•	DEC Only	•

Connecting the Scanner

Install the scanner by following the steps shown below:

- 1 Disconnect power to the terminal/computer by turning the host system power switch to the "OFF" position.

Power OFF

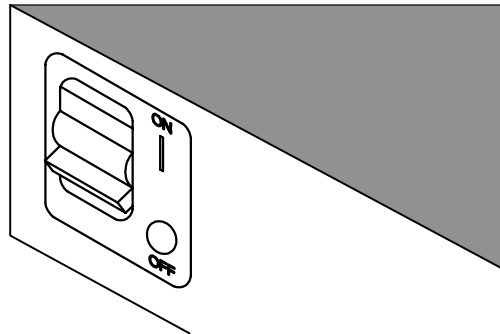

- 2 Connect the interface cable to the scanner and to the decoder unit attached to your terminal/computer.

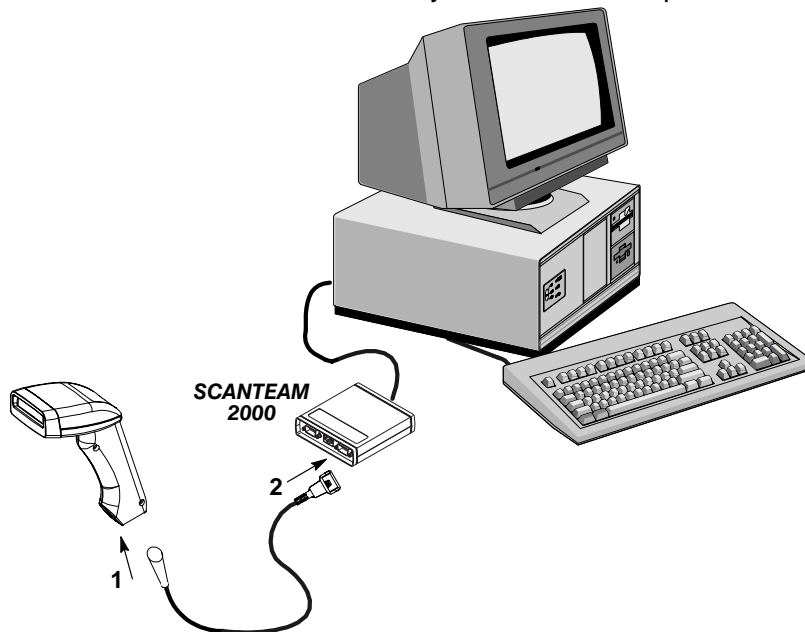

(Cable, Keyboard, and Terminal will vary.)

-
- ③ Once the scanner has been fully connected, restore power to the terminal/computer by turning the host system power switch to the “ON” position.

Power ON

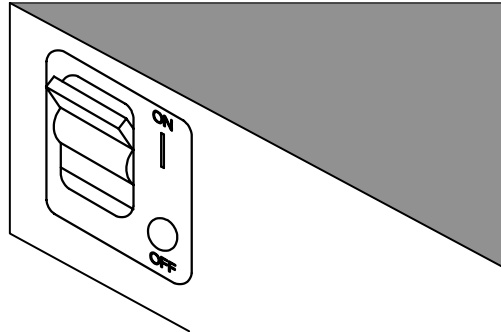

- ④ The 3400 is ready to scan bar code for your application.

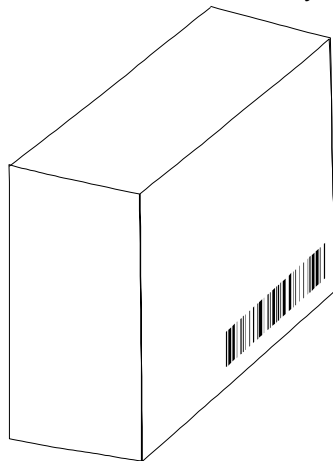

Scan Bar Code!

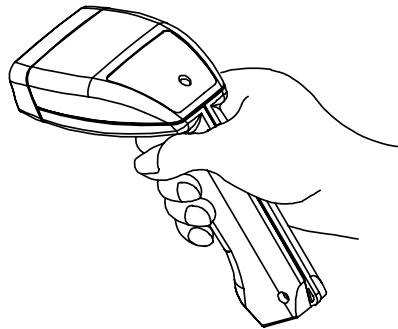

Scanning Techniques

The scanning technique for a single bar code (on a page or an object) is shown below.

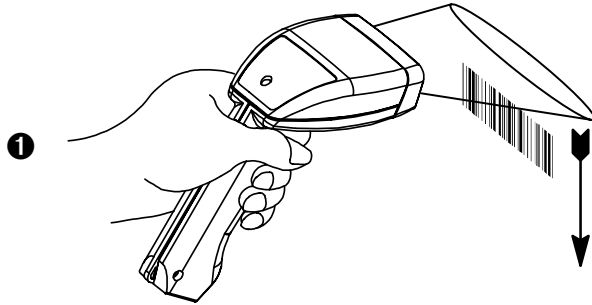

Single Bar Codes:
Move the 3400 Vertically

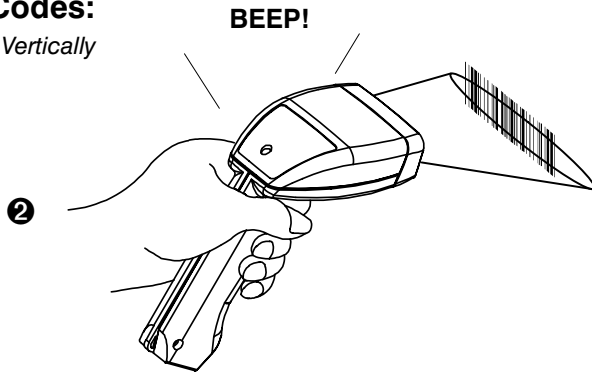

The illustration below shows where to aim the red illuminated beam over the bar code for a good read.

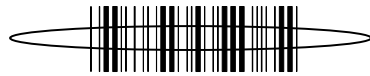

Correct



Incorrect

The scanning technique for multiple bar codes (on a page or object) is shown below.

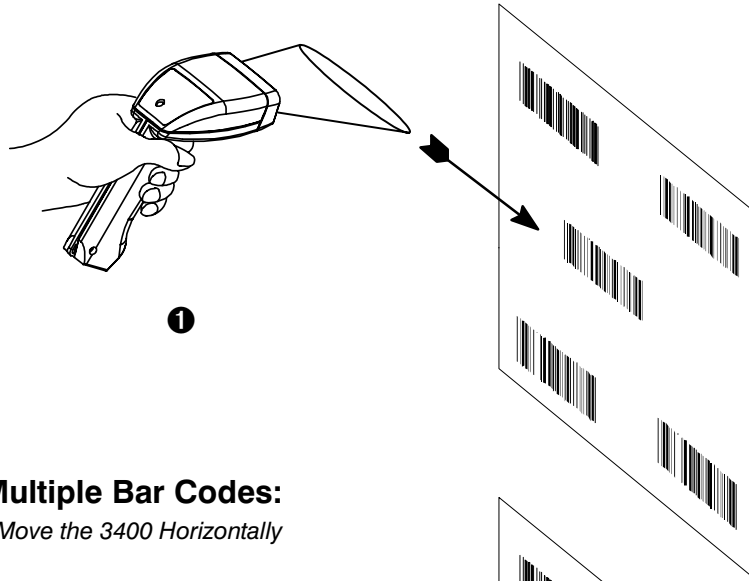

Multiple Bar Codes:

Move the 3400 Horizontally

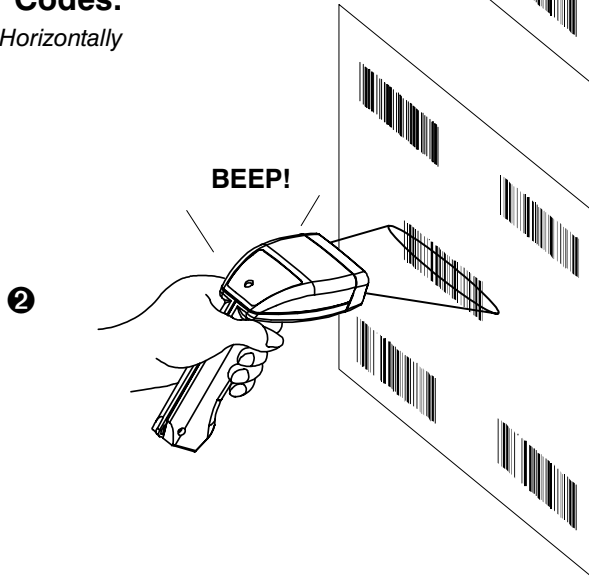

Note: *The techniques shown are for a 3400 with automatic trigger. To scan with a manual trigger, aim the 3400 at a bar code and press the trigger (like step 2).*

PRODUCT SPECIFICATIONS AND PINOUTS

Environmental Specifications

<i>parameter</i>	<i>specification</i>
Operating Temperature Storage Temperature	32° F to 122° F [0°C to 50°C] -40° F to 158° F [-40°C to 70°C]
Humidity	0% to 95% RH noncondensing
Barometric Pressure	101,000 to 69,000 Pascals [Sea level to 3,000 meters]
Mechanical Shock	Functional after ten 5ft. [1.5m] drops
ESD Sensitivity	Functional after 15KV discharge
Ambient Illumination	3,000 lux (in contact with bar code)
Modular Connector Life	750 insertions/disconnections

Electrical Specifications (3400-XX1, XX2)

<i>parameter</i>	<i>specification</i>
Operating Voltage	5 VDC \pm 10%
5VDC Input only Current Draw (3400-X0X)	50 Scans/Sec 100 Scans/Sec 55mA 80mA
Standby Current (3400/X-1XX)	less than 3mA
In-Rush Current	400mA maximum
Power Supply Noise Rejection	100mV peak to peak, from 10 to 100KHz
Acquisition Time (Trigger to Output)	100msec maximum
Mean Time Between Failure (MTBF)	50,000 hours (for ground benign)

Electrical Specifications (3400LR)

<i>parameter</i>	<i>specification</i>
Operating Voltage	5 VDC \pm 10%
5VDC Input only Current Draw (3400LR/F-103)	50 Scans/Sec 140mA
Standby Current (3400LR/F-103)	less than 3mA
In-Rush Current	400mA maximum
Power Supply Noise Rejection	100mV peak to peak, from 10 to 100KHz
Acquisition Time (Trigger to Output)	100msec maximum
Mean Time Between Failure (MTBF)	50,000 hours (for ground benign)

Scanner Performance (3400-XX1, XX2)

<i>parameter</i>	<i>specification</i>
Pitch Angle	±7 degrees
Skew Angle	±30 degrees
Minimum Reflective Difference (MRD)	37.5%
Scan Rate	100 or 50 scans per second (factory selectable)
Field Width	2.2 in [55mm] at near contact to 3.0 in [76mm] at 1 in [25mm] from scanner's nose
Horizontal Scan Velocity	0 to 5 inches [127mm] per second
Illumination	660 nm Visible Red Light Emitting Diodes (LED) with focusing reflector
Working Distance (3400-XX1)	Near contact for high density code
Working Distance (3400-XX2)	From contact to 4 in [10cm] for low to medium density code
Resolution (3400-XX1) (3400-XX2)	5 mil [0.127mm] code density minimum 20 mil [0.508mm] code density minimum

Scanner Performance (3400LR)

<i>parameter</i>	<i>specification</i>
Pitch Angle	±7 degrees
Skew Angle	±30 degrees
Minimum Reflective Difference (MRD)	37.5%
Scan Rate	50 scans per second
Field Width	2.2 in [55mm] at near contact to 5.0 in [127mm] at 5 in [127mm] from scanner's nose
Horizontal Scan Velocity	0 to 5 inches [127mm] per second
Illumination	660 nm Visible Red Light Emitting Diodes (LED) with focusing reflector
Working Distance (3400LR/F-1X3)	From contact to 6 in [15.24cm] for medium density code
Resolution (3400LR/F-1X3)	7 mil [0.178mm] code density minimum

Pinouts

❖ Laser Output *only*: 3400–X0X (Laser Compatible Bar Image)

8 Pin RJ41 Modular Connector
(in scanner handle)

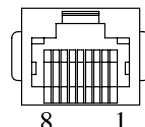

Pin	Standard Welch Allyn Color Code	Signal	Function
1	Braid	N/C	Cord Shield
2	Blue	Lasen	Laser Enable
3	Black	Ground	Supply Ground
4	Orange	Acknowledge	Turn on Good Read LED or Beeper
5	Green	Digout	Digital Bar Code Data Output
6	Red	+5VDC	5 Volt Power Connection
7	White	Trigger	Trigger Signal to Decoder
8	Gray	SOS	Start of Scan

❖ Standard Laser Cable: for 3400–X0X

Terminating Connector:
Standard 9 Pin (Type D)
Squeeze-to-Release Connector
(compatible with Welch Allyn terminals)

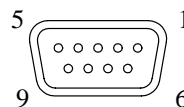

Pin	Standard Welch Allyn Color Code	Signal	Function
1	Grey	SOS	Start of Scan
2	Green	Data	Digital Bar Code Signal Output
3	Orange	ACK	Acknowledge – Good Read to Scanner
4	Red	+5VDC	Power to Scanner
5	White	Trigger	Trigger to Ground
6	Blue	Laser ON	Scan Enable
7	Black	GRND	Ground
8	Drain	Shield	Cord Shield Only
9	Red	no connection	Power to Scanner

General Dimensions

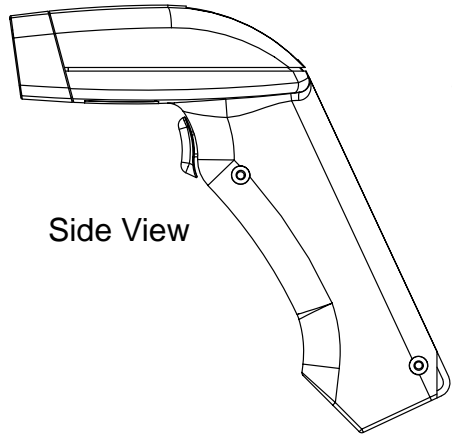

Side View

SCANTEAM 3400

Weight: 5.5 oz [155g]

*Belt Loop
(for portable applications)*

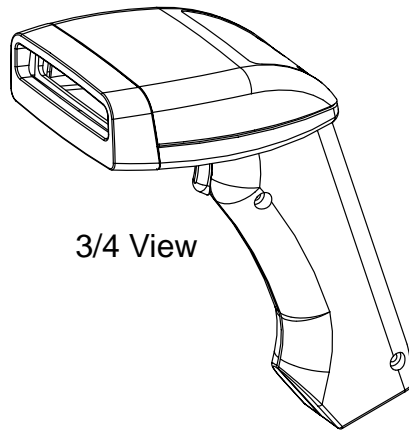

3/4 View

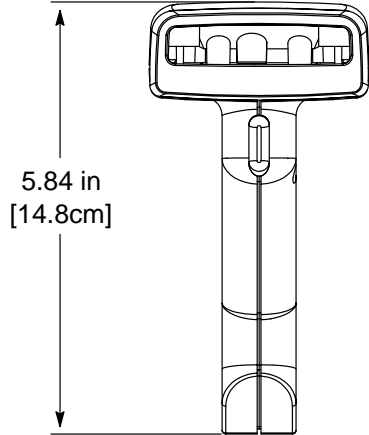

5.84 in
[14.8cm]

Front View

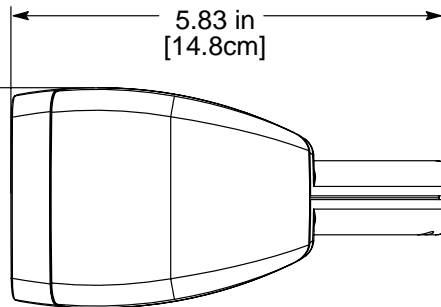

5.83 in
[14.8cm]

Top View

2.97 in
[7.5cm]

MAINTENANCE AND TROUBLESHOOTING GUIDE

Maintenance

The SCANTEAM 3400 provides reliable and efficient operation with a minimum of care. Although specific maintenance is not required, the following periodic checks insure dependable scanner operation:

❖ **Cleaning the Scan Window**

Scanning performance may degrade if the scan window is not clean. If the window is visibly dirty, or if the 3400 isn't scanning well, *clean the scan window with a soft cloth or facial tissue dampened with water (or a mild detergent-water solution)*. If a detergent solution is used, rinse with a clean tissue dampened with water only.

The scanner housing may also be cleaned the same way.



Caution:

Do not submerge the scanner in water. The scanner's housing is not water-tight.

Do not use abrasive wipers or tissues on the scan window: abrasive wipers may scratch the window.

Never use solvents (alcohol or acetone) on the housing or window: solvents may damage the finish or the window.

❖ **Inspecting Cords and Connectors**

Inspect the 3400's interface cable and connector for wear or other signs of damage. A badly worn cable or damaged connector may interfere with scanner operation. *Contact your Welch Allyn distributor for information about cable replacement.* Cable replacement instructions below....

❖ Replacing the Interface Cable

The standard interface cable is attached to the 3400 with an 8-pin modular connector. When properly seated, the connector is held in the scanner handle by a flexible retention tab. The cable's designed to be field replaceable.

Notes:

- Order replacement cables from Welch Allyn or from an authorized distributor.
- When ordering a replacement cable, specify the cable part number of the original interface cable.

To Replace the Interface Cable:

- ❶ Turn the power to the host system OFF.
- ❷ Disconnect the scanner cable from the terminal or computer.
- ❸ Locate the small hole on the side of the scanner handle near the base (see *Figure below*).
- ❹ Straighten one end of a paper clip.
- ❺ Insert the end of the paper clip into the small hole and press in. This depresses the retention tab, releasing the connector. Pull the connector out of the scanner handle while maintaining pressure on the paper clip.
- ❻ Replace with the new cable. Insert the connector into the opening at the base of the scanner handle. Press firmly. The connector is "keyed" to go in only one way, and will click into place.

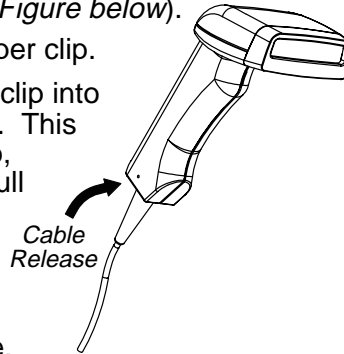

❖ Examining the Scanner Housing

Routinely examine the 3400 housing for signs of damage. A damaged housing may cause the internal components to move and may result in a malfunctioning scanner.

Troubleshooting

The SCANTEAM 3400 automatically performs self-tests whenever you turn it on. If your scanner is not functioning properly, review the following Troubleshooting Guide to try to isolate the problem.

Troubleshooting Guide

Is the power on? Is the red illuminated beam on?
If the red scan beam on the 3400 isn't illuminated, check that: <ul style="list-style-type: none">❶ the cable is connected properly.❷ the host system power is on (if external power isn't used).❸ the trigger works (if the 3400 is equipped with one).
Is the 3400 having trouble reading your bar codes?
If the 3400 isn't reading bar codes well, check that the bar codes: <ul style="list-style-type: none">❶ aren't smeared, rough, scratched, or exhibiting voids.❷ aren't coated with frost or water droplets on the surface.❸ are enabled in the decoder the 3400 is connected to.

LIMITED WARRANTY

Welch Allyn warrants its products to be functional and free from manufacturing defects at the time of delivery. Welch Allyn warrants that it will replace or repair, at its option, any SCANTEAM 3400 that fails to perform according to its published specifications during a period of three (3) years from the time of shipment by Welch Allyn (or from a Welch Allyn authorized distributor) to the user.

Any attempt on the part of the user to disassemble or service the scanner will void the warranty.

The warranty does not apply if, in the sole opinion of Welch Allyn, the scanner has been damaged by accident, misuse, neglect, improper shipping and handling. The warranty is valid only if the scanner has not been tampered with or serviced by any party unauthorized by Welch Allyn as a repair facility. The responsibility to protect the scanner from static damage is solely that of the user.

THE WARRANTIES SET FORTH HEREIN ARE IN LIEU OF ANY AND ALL OTHER WARRANTIES EXPRESSED OR IMPLIED INCLUDING THE WARRANTIES OF MERCHANTABILITY AND FITNESS FOR A PARTICULAR PURPOSE. THE BUYER ACKNOWLEDGES THAT NO OTHER REPRESENTATIONS WERE MADE OR RELIED UPON WITH RESPECT TO THE QUALITY AND FUNCTION OF THE PRODUCT HEREIN SOLD.

IN NO EVENT SHALL WELCH ALLYN OR ITS RESELLERS BE LIABLE FOR ANY LOSS, INCONVENIENCE OR DAMAGE WHETHER DIRECT, INCIDENTAL, CONSEQUENTIAL, OR OTHERWISE, AND WHETHER CAUSED BY NEGLIGENCE OR OTHER FAULT RESULTING FROM THE BREACH OF ANY EXPRESS WARRANTY EXCEPT AS SET FORTH HEREIN. SOME STATES DO NOT ALLOW THE EXCLUSION OR LIMITATION OF INCIDENTAL OR CONSEQUENTIAL DAMAGES, SO THE ABOVE LIMITATIONS OR EXCLUSIONS MAY NOT APPLY TO YOU.

This warranty gives you specific legal rights and you may also have other rights that vary from state to state or country to country.

❖ SAMPLE BAR CODES ❖

Codabar



0013557900

Code 39



TEST-SHEET

Interleaved 2 of 5



1234567890

Code 11



11223344

Code 128



CODE 128

UPC-A with 5 digit addenda

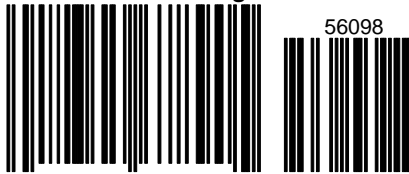

0 12345 67890 5

56098

UPC-E

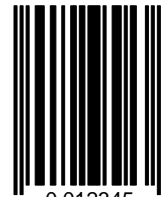

0 012345

UPC-A

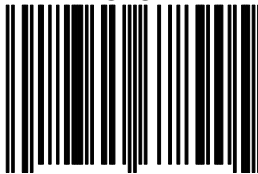

0 12345 67890 5

EAN 13

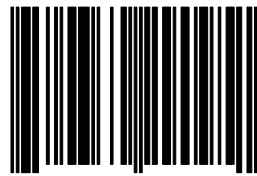

9 780330 290951



Welch Allyn



3400/LC/UG Rev E