

Welch Allyn ® SCANTEAM® 6980

RS-232 Interface
Magnetic Stripe Card Reader

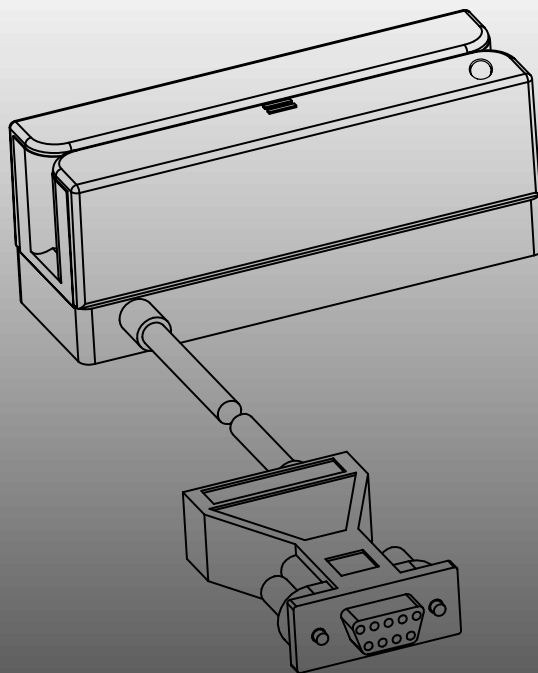

User's Guide

*Please Note: Finished document will be 5.5x8.5inches,
3-hole punched, folded and stapled.*

© 1998 Welch Allyn, Inc. All rights reserved.

Statements of Agency Compliance

This device complies with part 15 of the FCC Rules. Operation is subject to the following two conditions: (1) this device may not cause harmful interference, and (2) this device must accept any interference received, including interference that may cause undesired operation.

FCC Class A Compliance Statement

This equipment has been tested and found to comply with the limits for a Class A digital device, pursuant to part 15 of the FCC Rules. These limits are designed to provide reasonable protection against harmful interference when the equipment is operated in a commercial environment. This equipment generates, uses, and can radiate radio frequency energy and, if not installed and used in accordance with the instruction manual, may cause harmful interference to radio communications. Operation of this equipment in a residential area is likely to cause harmful interference, in which case the user will be required to correct the interference at his own expense.

Caution: Any changes or modifications made to this device that are not expressly approved by Welch Allyn, Inc. may void the user's authority to operate the equipment.

Note: To maintain compliance with FCC Rules and Regulations, cables connected to this device must be *shielded* cables, in which the cable shield wire(s) have been grounded (tied) to the connector shell.

Canadian Notice

This equipment does not exceed the Class A limits for radio noise emissions as described in the Radio Interference Regulations of the Canadian Department of Communications.

Le present appareil numerique n'emet pas de bruits radioelectriques depassant les limites applicables aux appareils numeriques de la classe A prescrites dans le Reglement sur le brouillage radioelectrique edicte par le ministere des Communications du Canada.



The CE mark on the product indicates that the system has been tested to and conforms with the provisions noted within the 89/336/EEC Electromagnetic Compatibility Directive.

TABLE OF CONTENTS

<i>Section</i>	<i>Page</i>
Statements of Agency Compliance	
Introduction	1
Features / Benefits	2
Applications	3
Configurations	3
Installation	4
Output Data Format	5
Configuration Options: Dip Switch Controlled ..	6
Accessing the 6980 DIP Switch	7
Dip Switch Feature Selection	8
Configuration Options: Download Controlled ...	8
Specifications	10
Pin Assignments	11
Service and Technical Support	12
Help Desk	13
Limited Warranty (inside back cover)	

Disclaimer

Welch Allyn[®] reserves the right to make changes in specifications and other information contained in this document without prior notice, and the reader should in all cases consult Welch Allyn to determine whether any such changes have been made. The information in this publication does not represent a commitment on the part of Welch Allyn.

Welch Allyn shall not be liable for technical or editorial errors or omissions contained herein; nor for incidental or consequential damages resulting from the furnishing, performance, or use of this material.

This document contains proprietary information which is protected by copyright. All rights are reserved. No part of this document may be photocopied, reproduced, or translated into another language without the prior written consent of Welch Allyn, Incorporated.

INTRODUCTION TO THE SCANTEAM 6980 1

Introduction

The SCANTEAM® 6980 products are decoded output Magnetic Stripe card Readers (MSRs) which attach to Personal Computers (PC) and other devices containing serial RS-232 interface ports. All magnetic stripe decoding and serial RS-232 interface electronics are contained in the compact SCANTEAM 6980 product enclosure.

The SCANTEAM 6980 is a bi-directional card reader, that is, it can read cards swiped in either direction through the card reader. The beeper and the LED included in the SCANTEAM 6980 indicate a good read or bad read to the operator. Versions are available which allow decoding single, dual, and triple track magnetic stripe cards.

Features / Benefits

Compact Size

- Mounts easily on keyboard or any flat surface. (hook and loop fastener installation kit included.)

Direct Serial RS-232 Interface

- No hardware or software modification to PC system required to add magnetic stripe reading capability.

Bi-directional Card Read

- Ease of use, reduces training time, allows greater flexibility in mounting device.
- User can enable or disable data tracks.

Communications Parameters Changeable via DIP Switches

- Allows the MSR's communication settings to be changed in the field to meet the interface specifications of your host equipment. Some of the communication parameters that may be set are:
baud rate, character data bit count, parity, and check sum.

Good Read / Bad Track / Error LED and Beeper

- Provides feedback to operator to indicating the following:

<i>Normal Operation</i>	Green LED
<i>Programming Mode</i>	LED off (LED will flash and beeper will sound once as each command key is pressed during programming)
<i>Good Read</i>	Green LED blinks and single beep
<i>Bad or Missing Track</i>	Orange LED and double beep
<i>Error</i>	Red LED and triple beep

Applications

The SCANTEAM 6980 offers a fast, easy, and accurate method of entering data contained on a magnetic stripe into a PC system. Retail POS credit and debit account number entry, bank teller automation, membership ID verification, access control, work-in-process data entry, labor and job tracking, and tool and equipment sign out are just a few of the possible applications for the SCANTEAM 6980.

Configurations

Single Track		
Model #	Mag Track	Connector: External Power Pack ⌘
6980-2 †	2	DB-9 Female ⌘ : Power Pack Included
6980-4 †	3	DB-9 Female ⌘ : Power Pack Included
Dual Track		
Model #	Mag Tracks	Host Interface: Connector Compatibility
6980-1	1 and/or 2	DB-9 Female ⌘ : Power Pack Included
6980-3	1 and/or 2	DB-9 Female ⌘ : Power Pack Not Included
6980-5 †	1 and/or 2	DB-9 Female ⌘ : Power Pack Not Included

† Not standard product. Please consult factory for availability.

⌘ When included, the power pack is a wall mount device with 110 vac primary, and a regulated +5 VDC secondary output.

⌘ Connector contains a molded-in power jack.

* Power must be supplied on pin 9 of the DB-9 connector.

Installation

All versions of the SCANTEAM 6980 depend on an external source of +5 VDC power to operate. Since most RS-232 interface ports don't provide a power source, an external + 5 VDC power supply must be plugged into the molded receptacle in the SCANTEAM 6980's interface connector for all versions, except the 6980-5 †.

The SCANTEAM 6980 is easily installed into a PC system in the following steps:

- 1) Turn the system power off.
- 2) Connect the MSR cable to the PC's 9 pin D male RS-232 port.
- 3) Connect the 5 VDC adaptor cable to the MSR and then plug the 5 VDC adaptor into a 120 vac receptacle.
- 4) The MSR can be mounted to the wall, the side of a PC, a keyboard, or simply to a counter with the hook and loop fastener strips included with the product. Alternatively, the screws holding the bottom plastic case on the MSR may be replaced with longer screws for mounting purposes.
- 5) Turn the system power on.
- 6) Configure your host device to accept RS-232 data on its RS-232 port.
- 7) Test the SCANTEAM 6980's host interface configuration by passing a magnetic stripe card through the SCANTEAM 6980. The magnetic stripe data should appear on your PC screen. If the data does not appear on the screen, you may have to modify the output data configuration of the SCANTEAM 6980 (see page 6, Configuration Options).

† *The SCANTEAM 6980-5 will only operate when the host device supplies power on pin 9 of its DB-9 RS-232 interface port.*

Output Data Format

Note: See DIP Switch Feature Selection chart on page 8 for factory default settings.

Character Frame:

Start Bit: One
Data Bit: 8, 7 (optional)
Parity: None, Odd, Even (optional)
Stop Bit: One

Single Track:

{STX} {SS} <**TRACK DATA**> {ES} {CHECKSUM OF DATA} {ETX}

Dual Track:

Track 2 data follows track 1 data **or** precedes track 3 data.

{STX} {SS} <**TRACK 1 or 2 DATA**> {ES} {CHECKSUM} {DLE}

{STX} {SS} <**TRACK 2 or 3 DATA**> {ES} {CHECKSUM} {ETX}

Triple Track:

Track 1 data followed by track 2 data, and then track 3 data.

{STX} {SS} <**TRACK 1 DATA**> {ES} {CHECKSUM} {DLE}

{STX} {SS} <**TRACK 2 DATA**> {ES} {CHECKSUM} {DLE}

{STX} {SS} <**TRACK 3 DATA**> {ES} {CHECKSUM} {ETX}

Where: <STX> = START OF TEXT CHARACTER

<DLE> = DATA LINK ESCAPE CHARACTER

<ETX> = END OF TEXT CHARACTER

SS = Start sentinel	%	Track 1 for ISO, CA DMV, AAMVA
	;	Track 2 for ISO, CA DMV, AAMVA
	;	Track 3 for ISO
	%	Track 3 for AAMVA
	!	Track 3 for CA DMV
ES = End sentinel	?	Tracks 1, 2, 3 for ISO, CA DMV, AAMVA

ISO = International Standards Organization (ISO # 7811)

CA DMV = California Department of Motor Vehicles

AAMVA = American Association of Motor Vehicle Administrators

Data characters in braces, “{ },” and not in boldface are optional.

Configuration Options: Dip Switch Controlled

The SCANTEAM 6980 contains a Dual In-Line Package (DIP) switch pack which is used to configure the operation of the reader. The position of these switches are pre-set by Welch Allyn and normally do not need to be changed by the user, unless the host device's RS-232 communication parameters do not match the SCANTEAM 6980's default settings (see page 8).

The DIP switches on the SCANTEAM 6980 control the following host interface parameters:

“SS” and “ES” characters

This parameter allows the “SS” and “ES” characters encoded on the magnetic stripe to be transmitted or not transmitted to the host PC.

RS-232 Data Bit and Parity Selection

This parameter allows you to change the MSR's serial RS-232 output parameters for character data bit count and parity. The following selections are available:

- 8 data bits and no parity,
- 7 data bits and even parity, or
- 7 data bits and odd parity.

RS-232 Baud Rate Selection

This parameter allows you to change the MSR's serial RS-232 output parameters for baud rate. The following selections are available:

- 1200 bps (bits per second),
- 2400 bps,
- 9600 bps, or
- 19200 bps.

Check Sum Selection

This parameter allows transmission of a checksum character (or no check sum) after the track data sent by the MSR.

In order to access the DIP switch pack, the DIP switch cover must be removed, exposing the switches.

Accessing the SCANTEAM 6980 DIP Switch

1. Remove the DIP switch cover (on the bottom of the MSR).

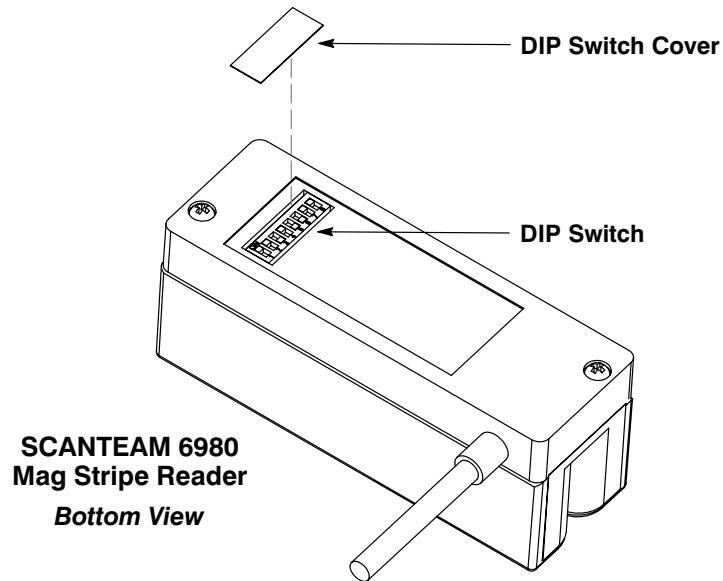

2. Set DIP switches to desired position.

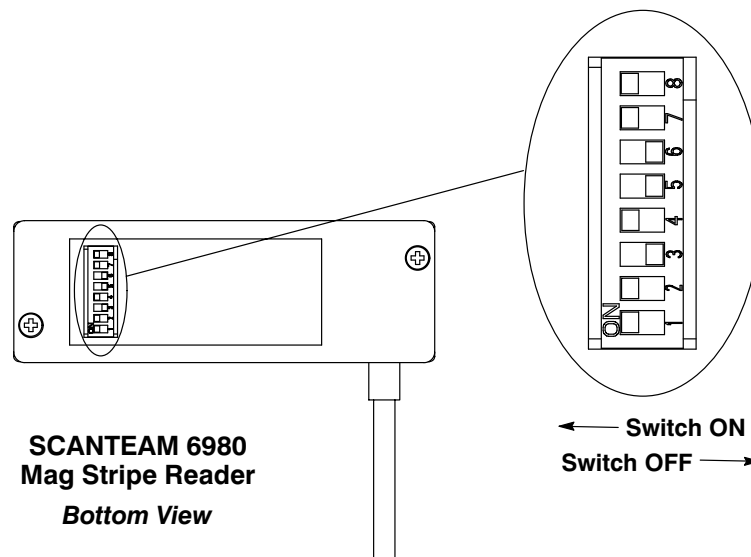

3. Re-install the DIP switch cover.

Dip Switch Feature Selection

Parameter	Configurations				
RS-232 Type Data Bit and Parity ②	Setting SW 1	8 Bit None ON*	Reserved OFF	7 Bit Even ON	7 Bit Odd OFF
	SW 2	ON*	ON	OFF	OFF
SS, ES Code	Setting SW 3	Enabled OFF*		Disabled ON	
RS-232 Type Baud Rate	Setting SW 4	1200 ON	2400 OFF	9600 ON*	19200 OFF
	SW 5	ON	ON	OFF*	OFF
Check Sum	Setting SW 6	Disabled OFF*		Enabled ON	
STX, ETX, DLE	Setting SW 7	Enabled ON*		Disabled OFF	
Mode	Setting SW 8	Normal Operating ON*		Programming OFF	

- Notes:**
- ① Asterisk (*) Indicates Factory Default Setting.
 - ② Data Format includes one Start Bit and one Stop Bit.

Configuration Options: Program Mode Download Controlled

The SCANTEAM 6980 Magnetic Stripe Reader has two operating modes: Normal Operation and Programming.

In Normal Operation mode, everything typed on a connected keyboard is passed to the host PC directly. A program utility is required for Programming mode. The utility will monitor the keys pressed and program the MSR via the RS-232 port. The green LED will flash and the MSR will beep as each command key is typed during programming.

In Programming mode, the following parameters are programmable:

- communication parameters
- beeper enable/disable
- MSR track decode selection

Note: *To set options in the "Programming" mode all commands MUST BE typed in with an AT type keyboard.*

Enabling or Disabling Track Configurations and / or Beeper

1. Turn off power to the SCANTEAM 6980. (If a PC provides power to the MSR, then turn the PC off.)
2. Set MSR DIP switch position 8 to OFF.
3. Turn on power to the MSR.
4. Run the software utility by typing the executable file name at the command line. The executable file is that shown on the SCANTEAM 6980 Programming Utility disk received with the MSR.

Example: **A:\MENU100A.EXE**

The disk is in drive A and the executable file name shown on the disk is "MENU100A.EXE."

5. Follow the setup instructions on the disk:
 - Select the COM port, baud rate, number of data bits and parity. Communication parameters selected must match those set by the switch selections of the MSR being programmed.
 - Select the track enable/disable configuration you need.
 - Enable or disable the beeper.
6. Turn off power to the MSR.
7. Set MSR DIP switch position 8 to ON.
8. Reapply power to the MSR.

Note: *Triple track enable/disable options are not available with a two track MSR.*

Specifications

Recording Method	Two-frequency coherent phase (F2F), compatible with ISO 7811
Swipe Speed	5 to 50 in/sec (worst case with $\pm 12\%$ jitter card), bi-directional
Power Requirements	Reader is low-power CMOS. Power is supplied by an external +5 VDC power pack to operate the reader.
Current Draw	60 mA @ +5 VDC maximum
Output	Data read from the magnetic stripe card is transmitted to the computer according to the Output Data Format (page 5) and the DIP Switch settings (page 8). (RS-232 decoded-out)
Operating Temperatures	14° F to 122° F (-10° C to 50° C)
Storage Temperatures	-22° F to 158° F (-30° C to 70° C)
Operating Humidity	10% to 90% relative humidity
Dimensions	Length 3.94 in (10.0 cm) Width 1.34 in (3.40 cm) Height 1.67 in (4.24 cm)
Weight	Approximately 10.6 oz. (300 g)
Cable Length	From card reader to computer, approximately 5 feet (150 cm).
Connector	9 pin D-subminiature connector
Magnetic Head Life	300,000 passes minimum (longer life version available)
Configuration Options	Contains an 8 position DIP switch which allows users to select host interface parameters (see table on page 8) and PC configuration utility.

Note: All models of the SCANTEAM 6980 require external power. The Configurations table on page 3 indicates which MSR models are shipped with a power pack.

Pin Assignments

All Models 6980: -1, -2 †, -3, -4 †, and -5 †

DB-9 Pin #	Function
1, 4, 6	Shorted together
2	TxD (transmitted data) from MSR
3	No connection
5	Signal Ground
7, 8	Shorted together
9	No connection on 6980-1, -2, -3, -4 +5 VDC power input on 6980-5 only
Shell	Shield

† Not standard product. Please consult factory for availability.

Software Revision History

The following table contains the SCANTEAM 6980 MSR's software revision history. The software revision of the SCANTEAM 6980 is printed on the label located on the bottom of the MSR.

Software Revision	Effective UG Date/Rev	Notes
6B50	prior to 10/24/96	CE version.
M100A005.HEX, D490	10/24/96 Rev D	Above plus: Programming Utility disk, Programmable track combination enable/disable.
M100B015.HEX, F4E8	1/1/97 Rev E	Above plus: LED, Programmable beeper enable/disable.
M100B016.HEX, F164	7/1/97 Rev F	Above plus: STX, ETX, DLE enable/disable.



Limited Warranty

Welch Allyn warrants its products to be functional and free from manufacturing defects at the time of delivery. Welch Allyn warrants that it will replace or repair, at its option, any SCANTEAM 6980 that fails to perform according to its published specifications during a period of one (1) year from the time of shipment by Welch Allyn (or from a Welch Allyn authorized distributor) to the user.

Any attempt on the part of the user to disassemble or service the reader will void the warranty.

The warranty does not apply if, in the sole opinion of Welch Allyn, the reader has been damaged by accident, misuse, neglect, improper shipping and handling. The warranty is valid only if the reader has not been tampered with or serviced by any party unauthorized by Welch Allyn as a repair facility. The responsibility to protect the reader from static damage is solely that of the user.

THE WARRANTIES SET FORTH HEREIN ARE IN LIEU OF ANY AND ALL OTHER WARRANTIES EXPRESSED OR IMPLIED INCLUDING THE WARRANTIES OF MERCHANTABILITY AND FITNESS FOR A PARTICULAR PURPOSE. THE BUYER ACKNOWLEDGES THAT NO OTHER REPRESENTATIONS WERE MADE OR RELIED UPON WITH RESPECT TO THE QUALITY AND FUNCTION OF THE PRODUCT HEREIN SOLD.

IN NO EVENT SHALL WELCH ALLYN OR ITS RESELLERS BE LIABLE FOR ANY LOSS, INCONVENIENCE OR DAMAGE WHETHER DIRECT, INCIDENTAL, CONSEQUENTIAL OR OTHERWISE, AND WHETHER CAUSED BY NEGLIGENCE OR OTHER FAULT RESULTING FROM THE BREACH OF ANY EXPRESS WARRANTY EXCEPT AS SET FORTH HEREIN. SOME STATES DO NOT ALLOW THE EXCLUSION OR LIMITATION OF INCIDENTAL OR CONSEQUENTIAL DAMAGES, SO THE ABOVE LIMITATIONS OR EXCLUSIONS MAY NOT APPLY TO YOU.

This warranty gives you specific legal rights and you may also have other rights which vary from state to state or country to country.



6980/UG Rev F
S/W: M100B016.HEX, F164

